

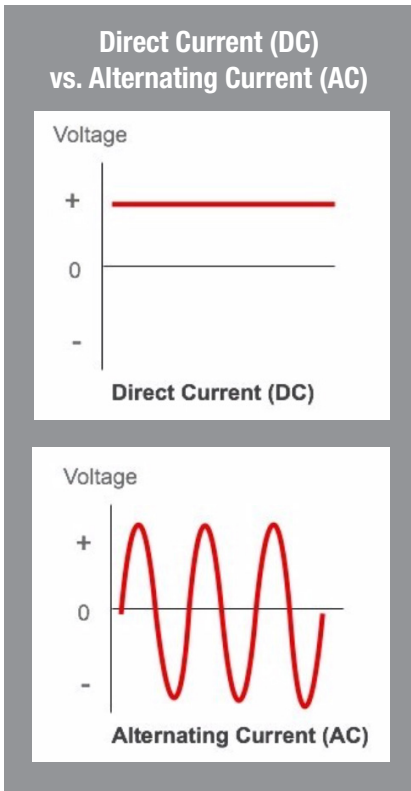

Automotive Ignition Coil: Progress Through Efficiency

The automotive ignition system is crucial to the internal combustion engine's operation and efficiency. At the heart of the entire ignition system is the ignition coil. To understand how ignition coils operate, it is important to have a general understanding of the basic principles of vehicle electronics.

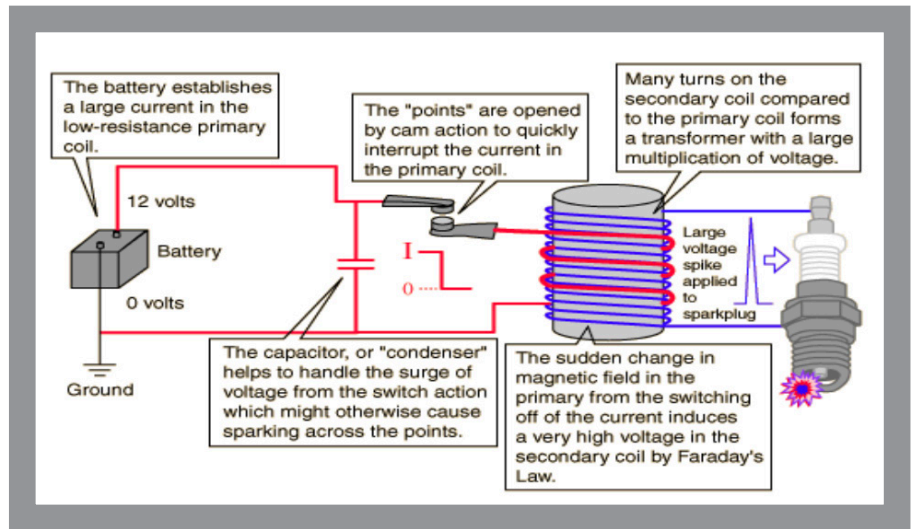

FARADAY'S LAW AND AUTOMOTIVE IGNITION

How do you obtain 40,000 volts across a sparkplug in an automobile when you have only 12 volts DC to start with? The essential task of firing the sparkplugs to ignite a gasoline-air mixture is carried out by a process which employs Faraday's Law.

The primary winding of the ignition coil is wound with a small number of turns creating a small resistance. Applying battery voltage to this coil causes a sizable DC current to flow. The secondary coil has a much larger number of turns and therefore acts as a step-up transformer. Rather than operating on AC voltages, this secondary coil is designed to produce a large voltage spike when the current in the primary coil is interrupted. Since the induced secondary voltage is proportional to the rate of change of the magnetic field through it, opening a switch quickly in the primary circuit to drop the current to zero will generate a large voltage in the secondary coil according to Faraday's Law. This large voltage spike what is used in the internal combustion engine to be sent to the spark plug. Once this voltage reaches the spark plug, the electricity arcs across the gap of the sparkplug to ignite the fuel mixture.

For many years, this interruption of the primary current was accomplished by mechanically opening a contact called the "points" in a synchronized sequence to send high voltage pulses through a rotary switch called the "distributor" to the sparkplugs. One of the drawbacks of this process was that the interruption of current in the primary coil generated an inductive back-voltage in that coil which tended to cause sparking across the points. The system was improved by placing a sizable capacitor across the contacts so that the voltage surge tended to charge the capacitor rather than cause destructive sparking across the contacts. Using the old name for capacitors, this particular capacitor was called the "condenser".

More modern ignition systems use a transistor switch instead of the points to interrupt the primary current. The transistor switches are contained in a solid-state ignition

Control Module. Modern coil designs produce voltage pulses up in the neighborhood of 40,000 volts from the interruption of the 12-volt power supplied by the battery.

COMMON IGNITION SYSTEM D ECHNOLOGICAL GENERATIONS STANDARD IGNITION COIL

The earliest design of ignition coil was also referred to as the “Can Style” coil, based on the general shape of the unit itself. This system was widely used on nearly all automotive makes and models with point style and electronic ignition systems. This was the primary ignition system from 1910 through 1985. Can style ignition systems operated on a 12V supply and worked in collaboration with a distributor system. The ignition coil had a positive and negative post that connected to the battery. Then, it had a spark plug wire that made the contact between the ignition coil and the distributor cap.

G.M. HEI IGNITION COIL

Through advancements in automotive technology, General Motors introduced the High Energy Ignition (HEI) system in 1969. GM’s HEI systems worked in collaboration with a distributor system like the can style systems (or standard ignition systems), but without the need for a spark plug wire going from the coil to the distributor. HEI coils have 2 wires protruding from them with terminals on the end that clip into the inside of the distributor cap to another wire harness that helps to make the connection between coil and distributor. This design for GM helped reduce engine bay clutter by removing the external coil and incorporating it as part of the distributor cap, as well as reduced an additional current path by removing the extra spark plug wire used in the standard ignition setup between coil and distributor.

IGNITION COIL PACK

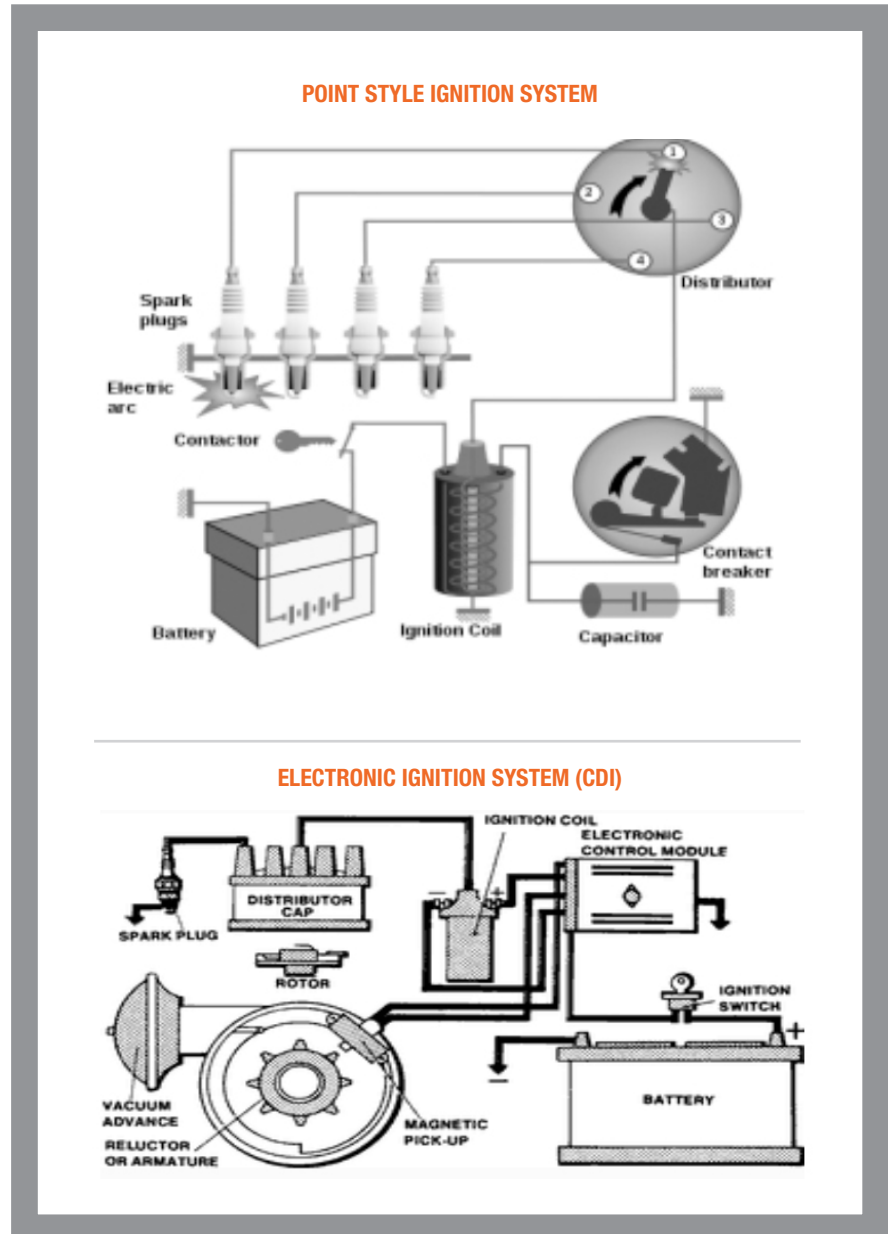

During the mid-80’s, automotive manufacturers had continued to develop more efficient engines, which required more efficient ignition systems. The coil pack ignition design was introduced to remove the mechanical connection from the engine to the coil via the distributor. Without the need of the distributor, these coil packs simply require spark plug wires to be routed from the coil pack to the spark plug. On some GM models, they are referred to coil near plug, where it’s a single coil for each cylinder but still requires a spark

plug wire to make the connection between the coil and spark plug. The benefit to this design is the deletion of the distributor, helping to improve engine bay efficiency and allowing the coil pack to be strategically positioned on the vehicle.

COIL ON PLUG IGNITION SYSTEM (COP)

The 1990’s represented many industry changes to create more fuel-efficient vehicles. While much of this is obtained in other departments, such as weight reduction,

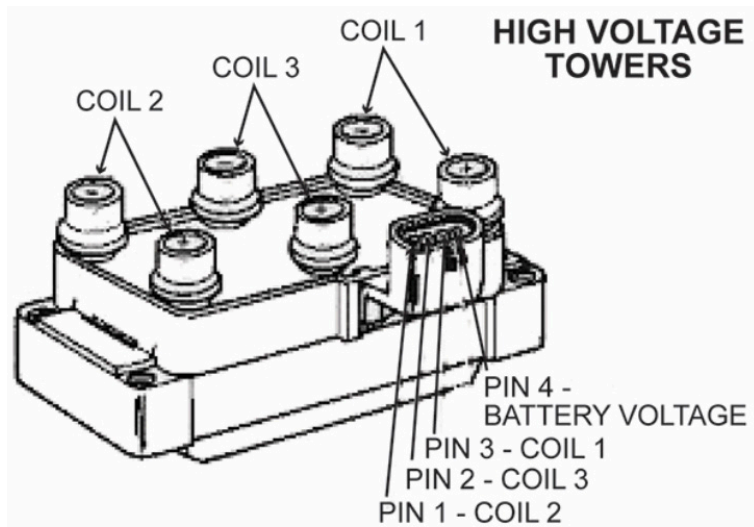
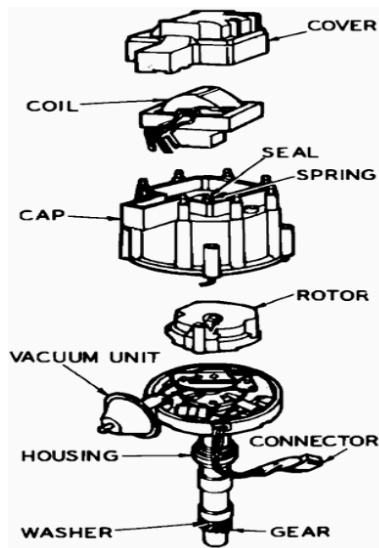

smaller engine displacements, and so forth, the fuel-efficiency can be greatly improved upon through the ignition and timing of the engine. The coil on plug ignition system was developed to be the most efficient method for spark production in the combustion process. As their name implies, they sit directly on top of your engine, directly in contact with the spark plug. There are several factors to why COP ignition systems are more efficient than their predecessors. Some of those reasons include the ability to replace individual coils as they fail, as opposed to replacing an entire coil pack because just one output failed. In addition, there is the added benefit of no longer needing spark plug wires, which reduces overall system components and unnecessary electrical resistance.

DELPHI IONIZATION CURRENT SENSING IGNITION SUBSYSTEM

Some modern COP systems were further advanced by Delphi in 2012 to monitor ionization current to determine a number of factors such as misfire detection, knock detection, fuel compensation, and proper

timing advance for the next firing sequence. These COP systems are capable of inducing over 50,000 volts if required (dictated by the required ionization current).

Delphi's Ionization Current Sensing Ignition Subsystem (Ion Sense) is a technology based on the principle that electrical current flow in an ionized gas (e.g. during combustion) is proportional to the flame electrical conductivity. By placing a direct current bias on the spark plug electrodes, the conductivity can be measured.

With Ion Sense technology, the conventional spark plug acts as an intrusive sensor in the cylinder to obtain information about each combustion event with minimal influence due to environmental conditions such as vibration, mechanical noise, and temperature. Optimized individual cylinder knock control helps increase engine efficiency and reduce fuel consumption. Through this Ion Sense technology, misfire detection is OBD II capable and provides very high reliability and robustness compared to many other detection methods.

Advanced features of Ion Sense Subsystems, such as compensation of combustion due to fuel variation, are also available to help reduce cold-start HC tailpipe emissions.

IGNITION COIL MATERIALS AND CONSTRUCTION

Potting Materials

The potting materials have changed dramatically since the ignition coils inception; originally ignition coils were paper insulated wiring coils mounted in wood or steel boxes. Later the ignition coil was built into the familiar conical shape and filled and formed with a phenolic plastic potting material to protect it from vibration and heat.

The potting materials have changed from phenolic plastic, epoxies, urethane polymers, and most recently to DuPont Rynite® and Thermx®. The materials may look like the same black plastic, but they have evolved dramatically. Some early ignition coils were oil cooled (the windings were submerged in oil), which could leak and cause overheating and coil failure; but all modern ignition coils are now dry due to improvements

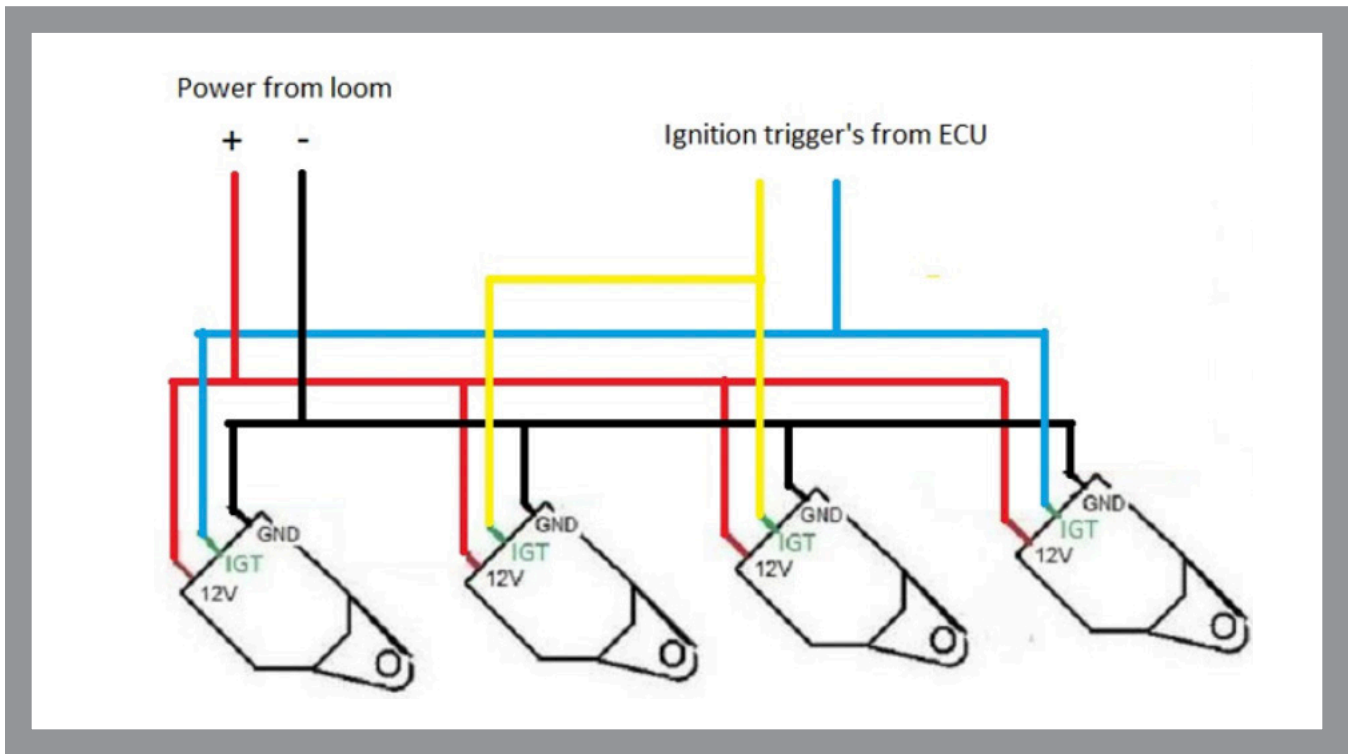

in core materials, coil winding materials, and potting materials that can withstand higher under hood temperatures, vibration, and higher secondary voltage.

Coil Winding Materials

Primary and secondary coil windings use an insulated copper or

copper coated aluminum wire. Originally the windings were insulated with paper or cloth. Most modern coil windings are now insulated with polyurethane or polyamide enamel composites.

Magnetic Cores

All ignition coils have a magnetic

core made of ferromagnetic metal such as iron, or ferromagnetic compounds such as ferrites to concentrate the strength and increase the effect of magnetic fields produced by the electric current.

The presence of the magnetic core can increase the magnetic field of a coil by a factor of several thousand over what it would be without the core.

CONCLUSION

It is easy to see the advancements in technology throughout the years. As we continue to evolve the internal combustion engine to be more and more efficient, components such as ignition systems must also continue forward. Because there are so many variations of ignition coils in the automotive aftermarket today, Walker has committed to providing a full line of OE quality replacements for all makes and all models. Through quality, coverage, and support, Walker Products can provide the necessary resources to grow your business.

