

# INSTRUCTION SHEET

## OFF VEHICLE CARBURETOR SERVICE

### ROCHESTER MODELS M4MC, M4MCA, M4MEA

#### GENERAL EXPLODED VIEW

THE GENERAL DESIGN AND PARTS SHOWN WILL VARY TO  
INDIVIDUAL UNITS COVERED ON THIS INSTRUCTION SHEET

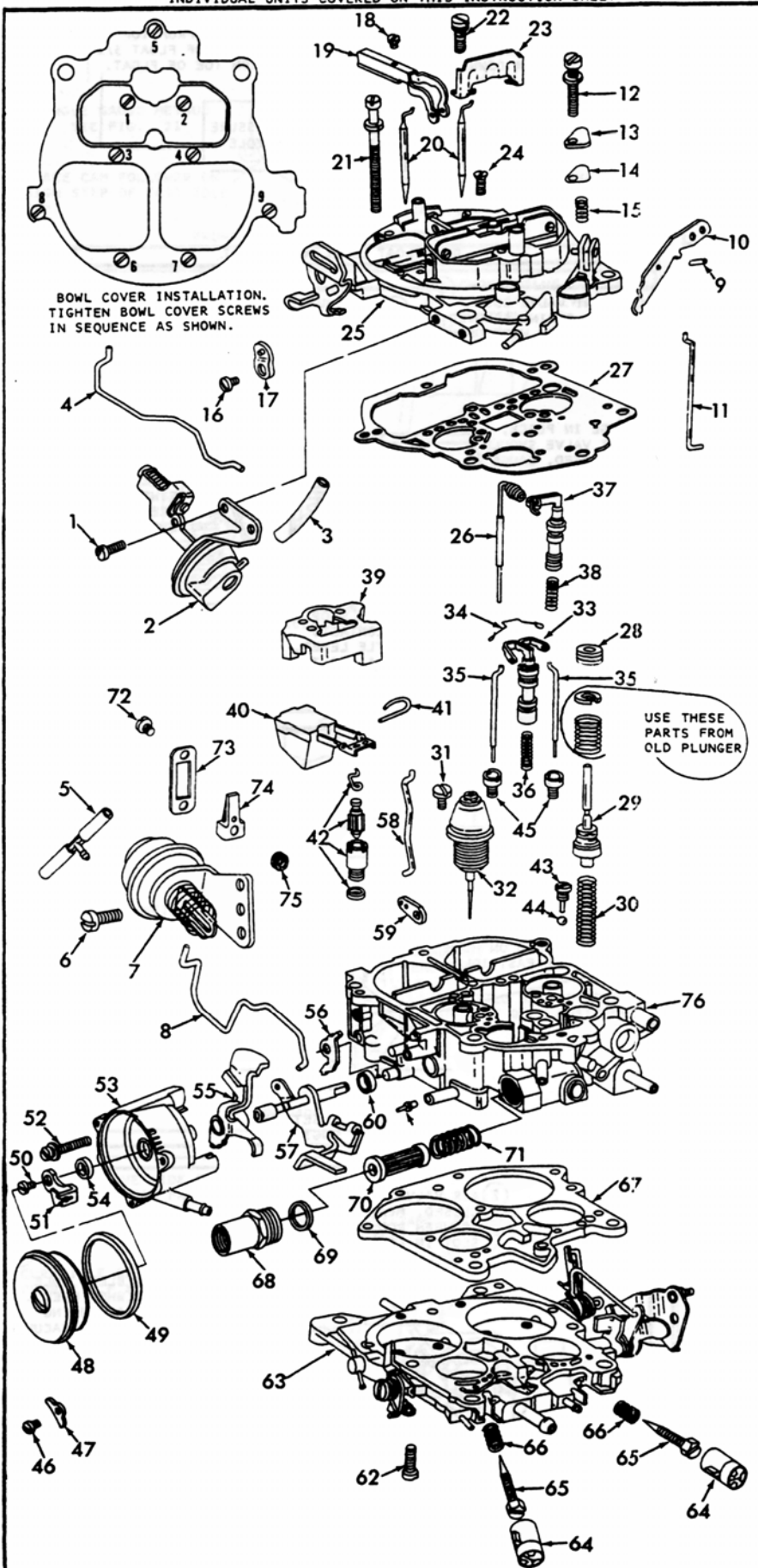

#### DISASSEMBLY

USE EXPLODED VIEW AS A GUIDE. THE NUMERICAL SEQUENCE MAY GENERALLY BE FOLLOWED TO DISASSEMBLE UNIT FAR ENOUGH TO PERMIT CLEANING AND INSPECTION. NOTE: PUMP LEVER PIN (9) CAN BE DRIVEN IN UNTIL IT RELEASES PUMP LEVER (10). BOWL COVER SCREWS (24) ARE LOCATED INSIDE OF THE AIR HORN. ON MODELS WITH AUXILIARY METERING ROD (26). PUSH TOP OF ROD TO ONE SIDE TO UNHOOK IT FROM ITS HOLDER BEFORE REMOVING BOWL COVER GASKET (27). ANEROID OR FILLER SPOOL METERING ROD ASSY. (32) IS FRAGILE AND SHOULD BE HANDLED GENTLY. THE UNITS ARE FACTORY-ADJUSTED AND EXTREMELY CRITICAL. NO ADJUSTMENT SHOULD BE ATTEMPTED. REPLACED WITH A SPACER ON 1976 MODELS. POWER PISTON ASSYS. (33)(37) CAN BE REMOVED BY CAREFULLY PRYING OUT OR BY BOUNCING PISTON. CAUTION: ON MODELS USING A MAIN AND AUXILIARY POWER PISTON, BE SURE AND MARK POWER PISTON SPRINGS (36)(38) AS THEY ARE REMOVED. THEY ARE NOT INTERCHANGEABLE. PRIMARY MAIN JETS (45) ARE THE ONLY JETS REMOVABLE. IDLE LIMITER CAPS (64) CAN CAREFULLY BE REMOVED BY CUTTING OFF WITH PLIERS. NO REPLACEMENT CAPS ARE NECESSARY AS A BARE MIXTURE NEEDLE IS SUFFICIENT TO INDICATE THAT THE MIXTURE HAS BEEN READJUSTED. BEFORE REMOVING IDLE ADJUSTING NEEDLES (65) TURN EACH NEEDLE IN AND COUNT THE NUMBER OF TURNS IT TAKES TO SEAT EACH NEEDLE (RECORD). 1976 MODELS HAVE A P.P.T. ADJUSTMENT SCREW LOCATED DIRECTLY IN FRONT OF POWER PISTON. NO ATTEMPT SHOULD BE MADE TO READJUST. FACTORY ADJUSTED TO MEET EMISSION REQUIREMENTS.

#### NOMENCLATURE

REF. NO.	REF. NO.
1. SCREW (2)-FRONT VACUUM BREAK	38. SPRING-AUX. POWER PISTON
2. FRONT VACUUM BREAK ASSY.	39. INSERT - FLOAT BOWL
3. HOSE-FRONT VAC. BREAK UNIT	40. FLOAT & LEVER ASSY.
4. CONNECTING ROD-FRONT VAC. BREAK	41. HINGE PIN - FLOAT
5. HOSE-REAR VAC. BREAK	42. NEEDLE, SEAT, & GASKET ASSY.
6. SCREW (2)-REAR VAC. BREAK	43. PLUG-PUMP DISC. BALL
7. REAR VACUUM BREAK ASSY.	44. BALL - PUMP DISC.
8. CONNECTING ROD-REAR VAC. BREAK	45. JET (2) - PRIMARY MAIN
9. PIN-PUMP LEVER	46. SCREW (3)-CHOKE COVER RETAINER
10. LEVER - PUMP	47. RETAINER (3)-CHOKE COVER
11. ROD - PUMP	48. CHOKE COVER ASSY.
12. SCREW & LOCKWASHER - VENT COVER	49. GASKET - CHOKE COVER
13. COVER - VENT VALVE	50. SCREW - STAT COIL LEVER
14. GASKET - COVER	51. LEVER - STAT COIL
15. SPRING - VENT VALVE	52. SCREW & WASHER-CHOKE HOUSING
16. SCREW - CHOKE LEVER	53. CHOKE HOUSING
17. LEVER - CHOKE SHAFT	54. SEAL-CHOKE HOUSING
18. SCREW-SEC. METERING ROD HOLDER	55. CAM - FAST IDLE
19. HOLDER-SEC. METERING RODS	56. CAM - SECONDARY LOCKOUT
20. METERING ROD (2)-SECONDARY	57. SHAFT ASSY.-INTERMEDIATE CHOKE
21. SCREW & LOCKWASHER (2)-BOWL COVER (LONG)	58. ROD - CHOKE
22. SCREW & LOCKWASHER (4)-BOWL COVER	59. LEVER-INTERMEDIATE CHOKE
23. BAFFLE - AIR	60. SEAL-INTERMEDIATE CHOKE SHAFT
24. SCREW (2) - BOWL COVER (TAPERED HEAD)	61. TUBE - VACUUM PASSAGE
25. BOWL COVER ASSY.	62. SCREW & LOCKWASHER (2) - THROTTLE BODY
26. METERING ROD (1) - AUXILIARY	63. THROTTLE BODY ASSY.
27. GASKET - BOWL COVER	64. CAP (2) - IDLE LIMITER
28. SPACER - PUMP STEM	65. NEEDLE (2)-IDLE ADJUSTING
29. PUMP ASSY.	66. SPRING (2) - IDLE ADJ. NEEDLE
30. SPRING - PUMP RETURN	67. GASKET - THROTTLE BODY
31. SCREW (2)-ANEROID ASSY.	68. FILTER NUT-FUEL INLET
32. ANEROID ASSY.(SPACER 1976)	69. GASKET-FILTER NUT
33. POWER PISTON ASSY.-MAIN	70. FILTER - FUEL
34. SPRING - METERING ROD	71. SPRING - FUEL FILTER
35. METERING ROD (2)-MAIN	72. SCREW (2) - COVER
36. SPRING-MAIN PISTON ASSY.	73. COVER - IDLE COMPENSATOR
37. POWER PISTON ASSY. - AUXILIARY	74. IDLE COMPENSATOR ASSY.
	75. GASKET - IDLE COMPENSATOR
	76. FLOAT BOWL ASSY.

\* ITEMS NOT NORMALLY FOUND ON ALL MODELS.

#### CLEANING

CLEANING MUST BE DONE WITH CARBURETOR DISASSEMBLED. SOAK PARTS LONG ENOUGH TO SOFTEN AND REMOVE ALL FOREIGN MATERIAL. USE A CARBURETOR CLEANING SOLVENT. MAKE CERTAIN THE THROTTLE BORES ARE FREE OF ALL CARBON DEPOSITS. RINSE OFF IN SUITABLE SOLVENT. BLOW OUT ALL PASSAGES IN CASTINGS WITH COMPRESSED AIR AND CHECK CAREFULLY TO INSURE THOROUGH CLEANING OF OBSCURE AREAS. CAUTION: DO NOT SOAK FILLER SPOOL OR ANEROID ASSY. (32), FLOAT (40), DIAPHRAGM UNITS (2) (7), OR PARTS MADE OF RUBBER OR PLASTIC IN CLEANING SOLVENTS. DO NOT SAND, WIRE BRUSH, OR FILE ON TEFLON-COATED PARTS.

#### REASSEMBLY

REASSEMBLE IN REVERSE ORDER OF DISASSEMBLY. NOTE SPECIAL INSTRUCTIONS AND FOLLOW NUMERICAL OUTLINE IN MAKING ADJUSTMENTS NECESSARY FOR CARBURETOR BEING SERVICED.

#### SPECIAL INSTRUCTIONS

SPECIAL INSTRUCTIONS SEE NEXT PAGE.

# ADJUSTMENTS

## SPECIAL INSTRUCTIONS

FUEL FILTER NUT & GASKET (68) (69)- INSTALL AND TIGHTEN SECURELY (18 FT. LBS.). DO NOT OVER-TIGHTEN.

IDLE ADJUSTING NEEDLES (65)- TURN EACH NEEDLE IN UNTIL LIGHTLY SEATED, THEN BACK OUT THE NUMBER OF TURNS COUNTED AT DISASSEMBLY (ALTERNATE 3-4 TURNS OUT).

SEALS, INTERMEDIATE CHOKE SHAFT (60) (54)- SEAL (60) INSTALL WITH LIP FACING OUT. SEAL (54) INSTALL WITH LIP FACING IN.

CHOKE COVER ASSY. (48)- DO NOT INSTALL COVER UNTIL CHOKE LINKAGE ADJUSTMENTS ARE MADE. CAUTION: ELECTRIC CHOKE MODELS DO NOT USE A CHOKE COVER GASKET (49) BETWEEN THE ELECTRIC CHOKE ASSY. AND HOUSING

FLOAT INSTALLATION- INSTALL FLOAT BY SLIDING FLOAT LEVER UNDER PULL CLIP FROM FRONT TO BACK, INSTALL FLOAT PIN (DO NOT INSTALL PULL CLIP IN HOLES OF FLOAT ARM).

POWER PISTON ASSYS. (33) (37)- PRESS DOWN FIRMLY ON PLASTIC POWER PISTON RETAINER TO BE SURE IT IS FLUSH WITH TOP OF BOWL CASTING.

BOWL COVER INSTALLATION-TIGHTEN BOWL COVER SCREWS IN SEQUENCE AS SHOWN.(SEE EXPLODED VIEW).

REFER TO DECAL IN ENGINE COMPARTMENT FOR CORRECT TUNE UP PROCEDURE AND SPECIFICATIONS.

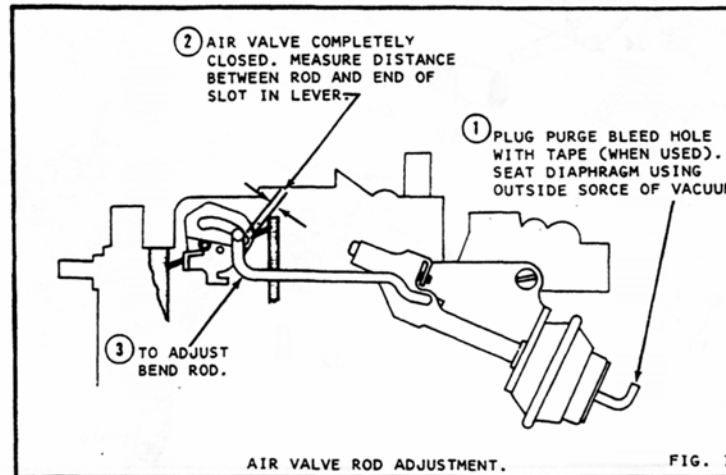
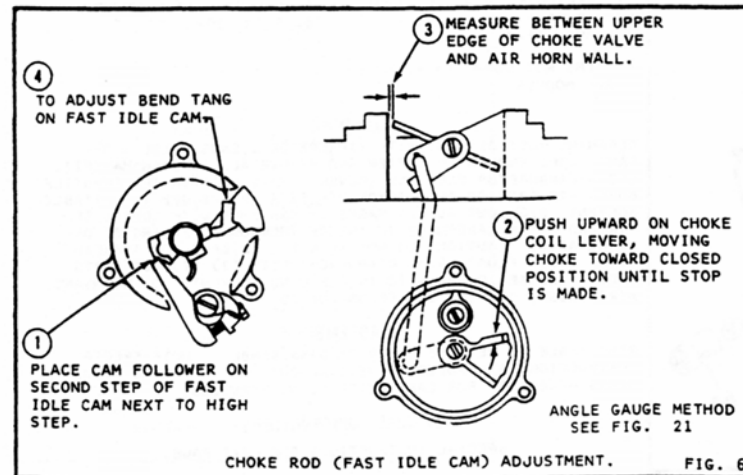
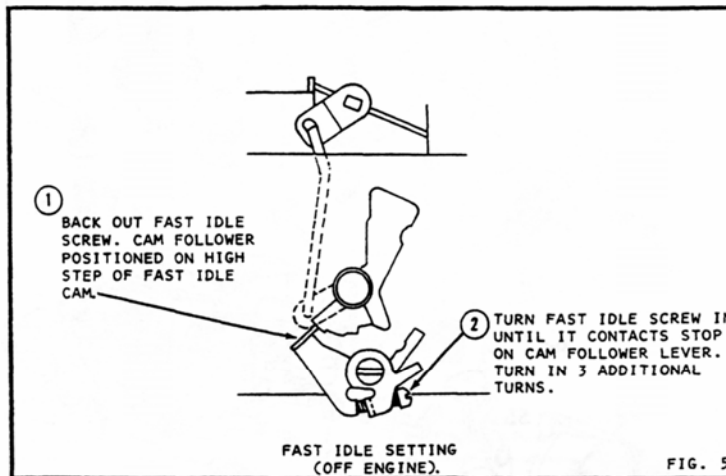
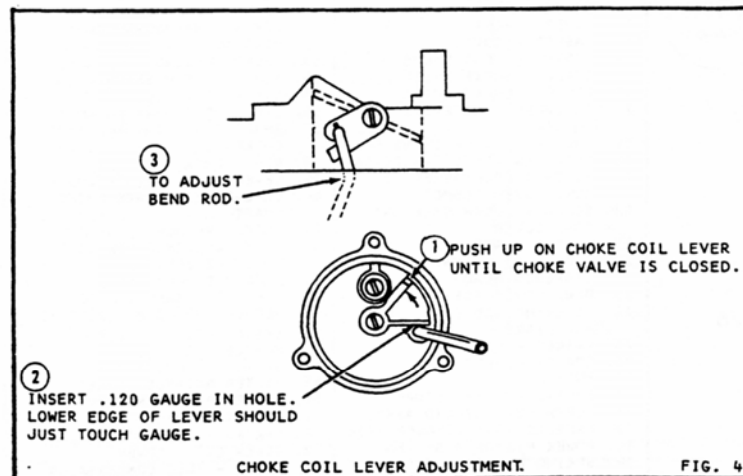
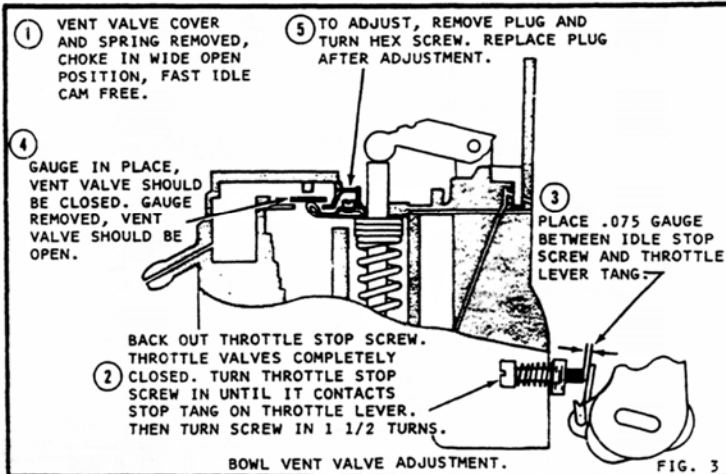
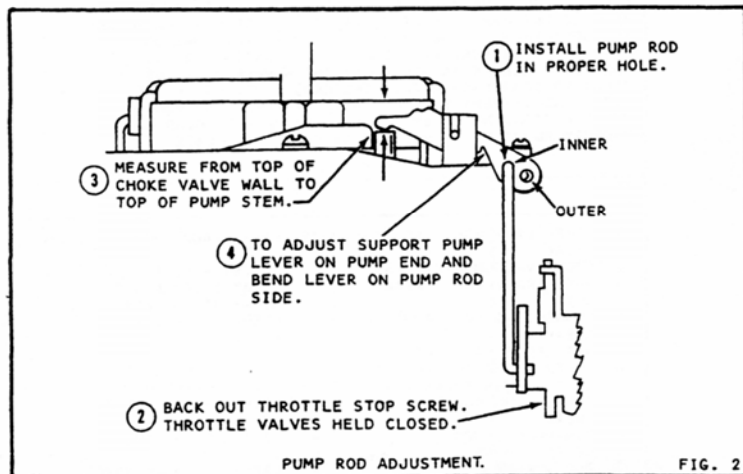
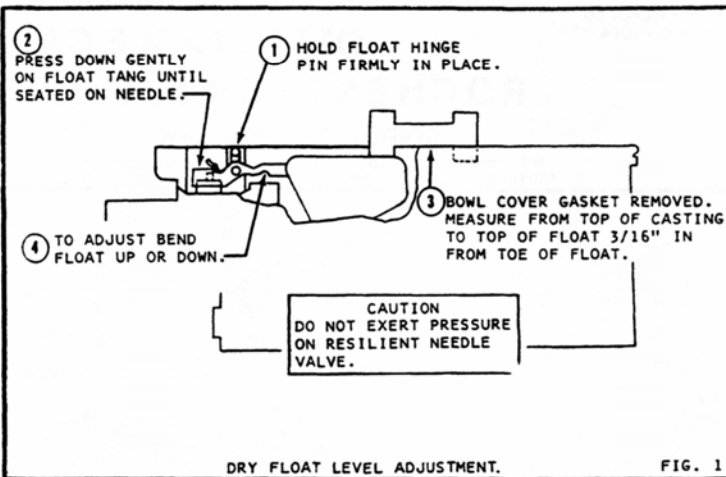

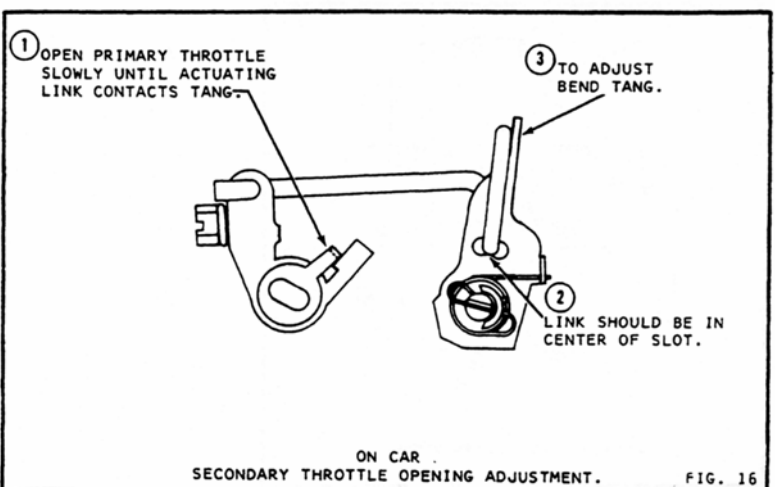
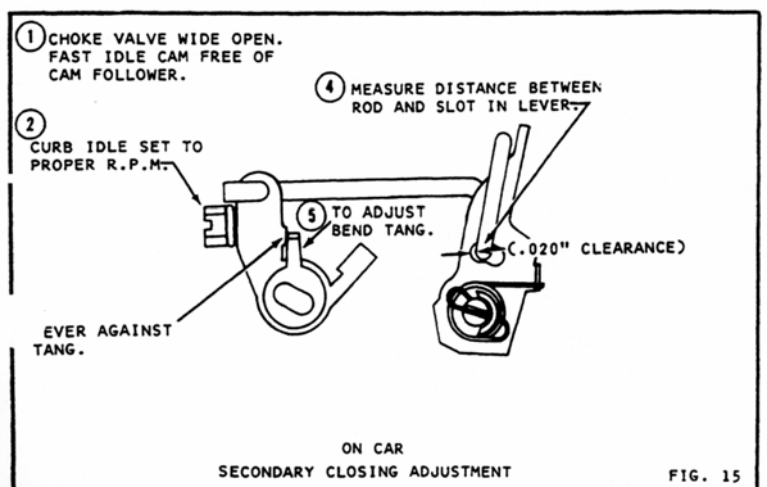
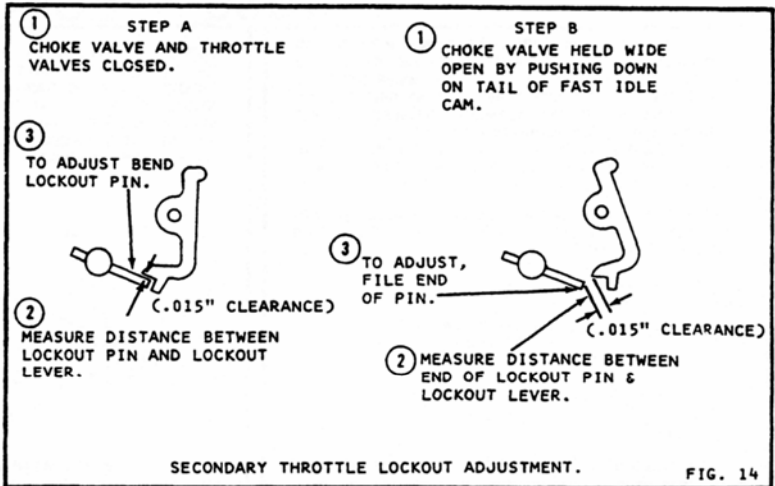
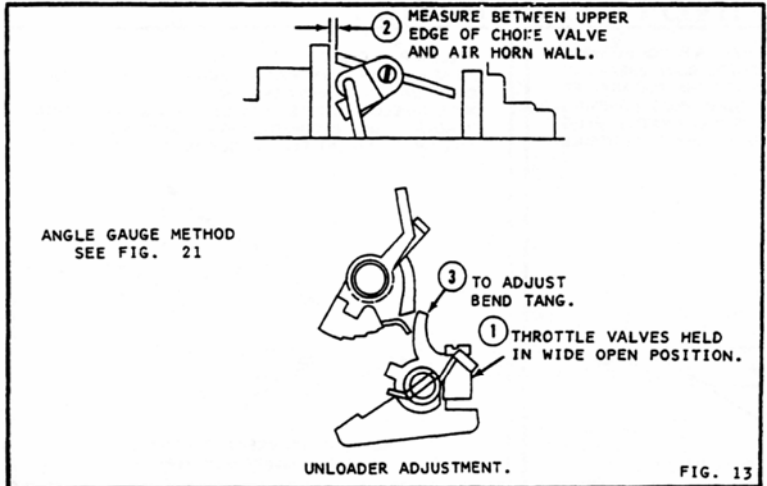
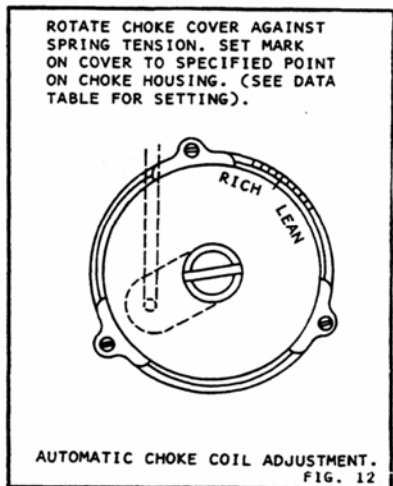
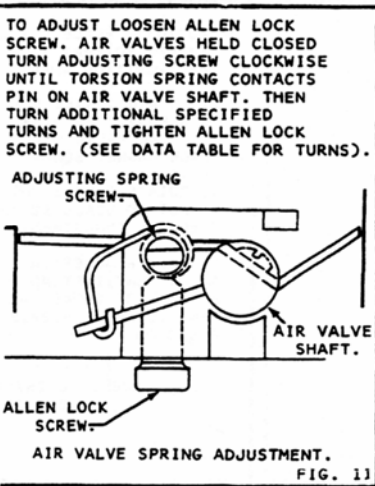
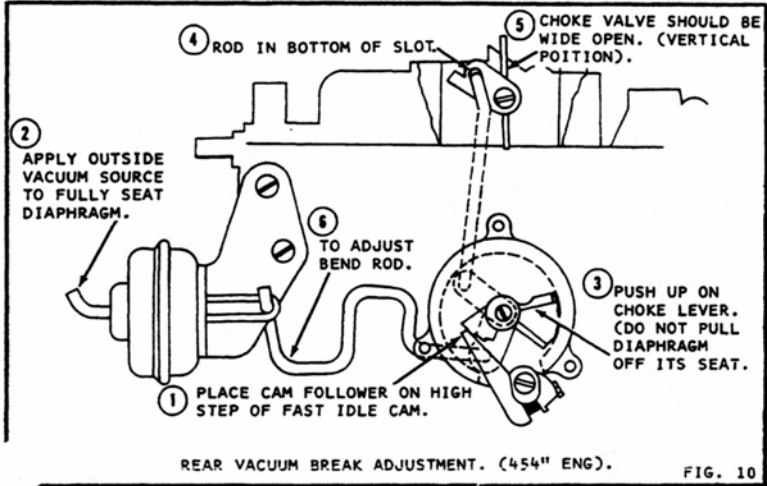
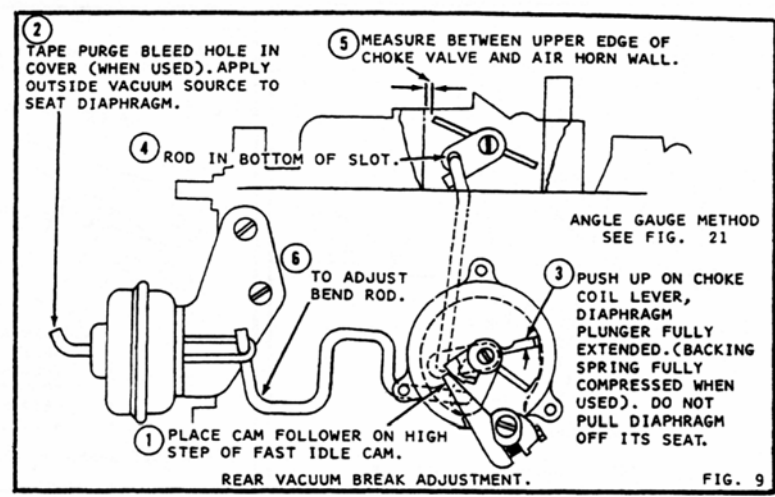
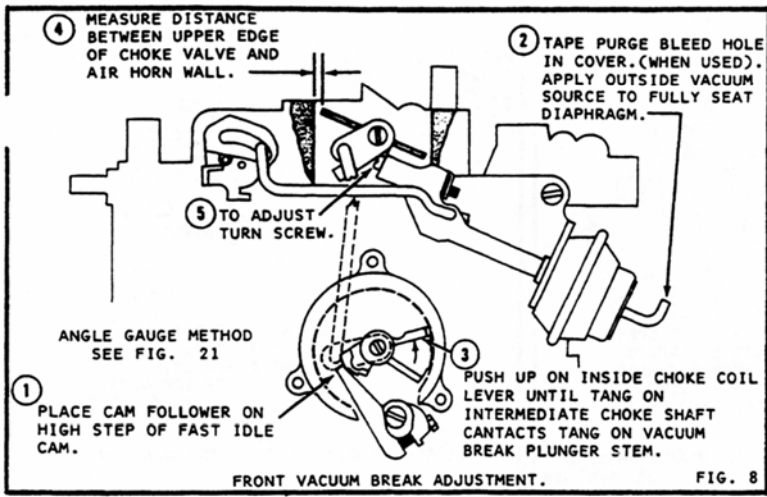

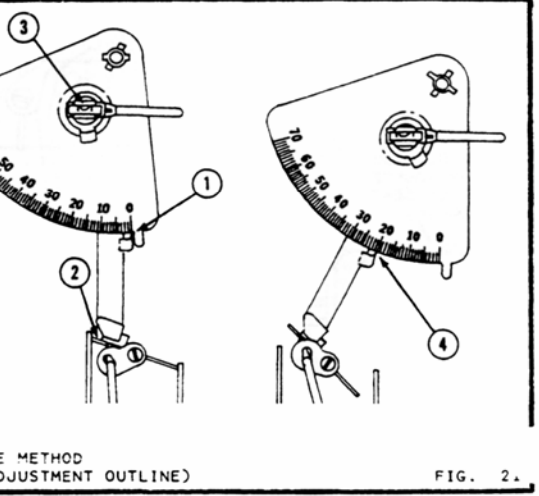
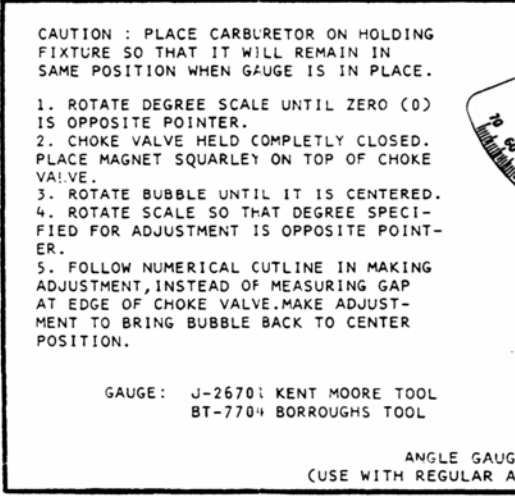
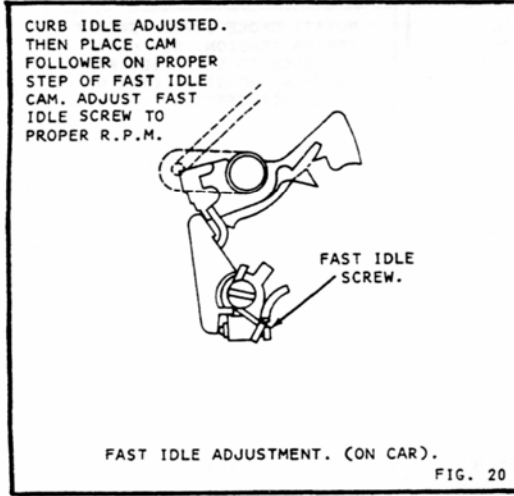
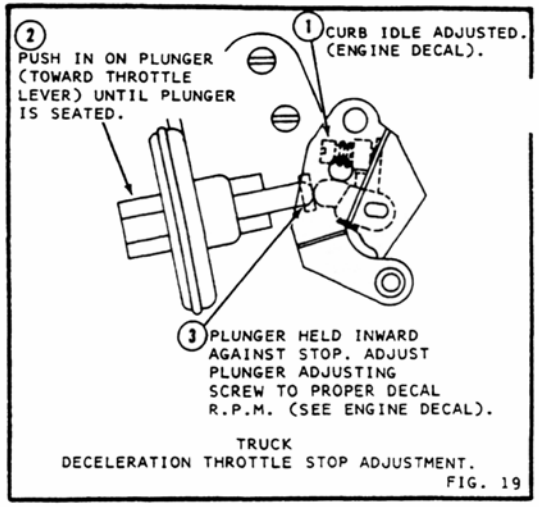
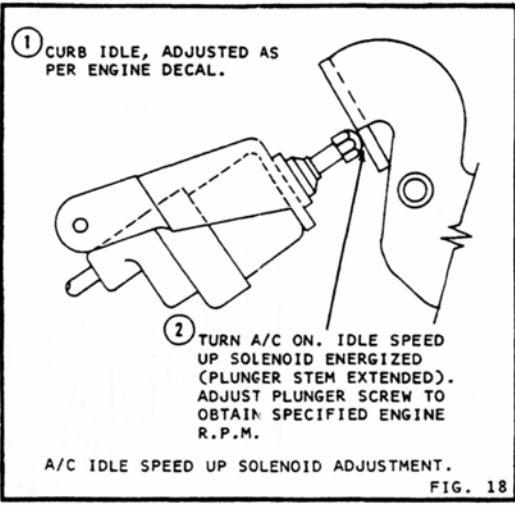
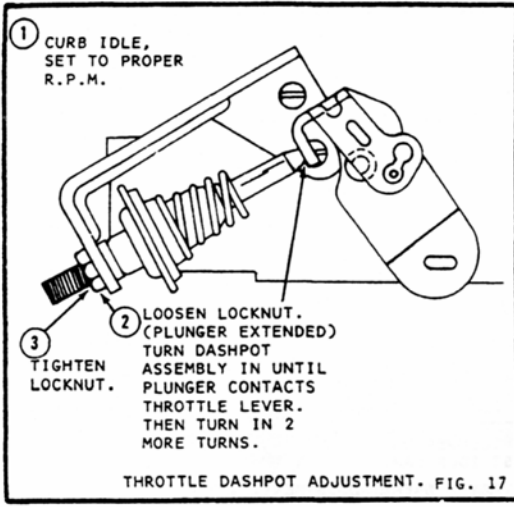

# 1980 SPECIAL INSTRUCTIONS.

