





**REFERENCE**



**WALKER CARBURETOR  
KIT #15565**



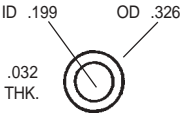
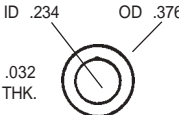
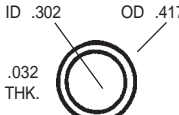

**NIKKI**

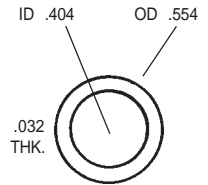
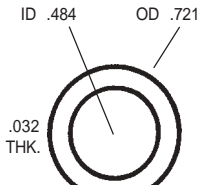
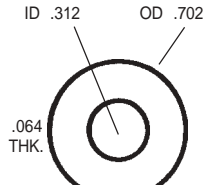
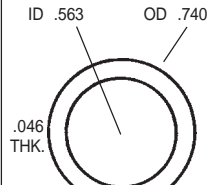
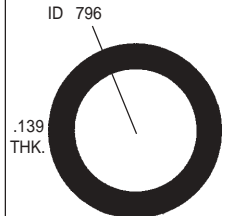
**"APPLICATION"**

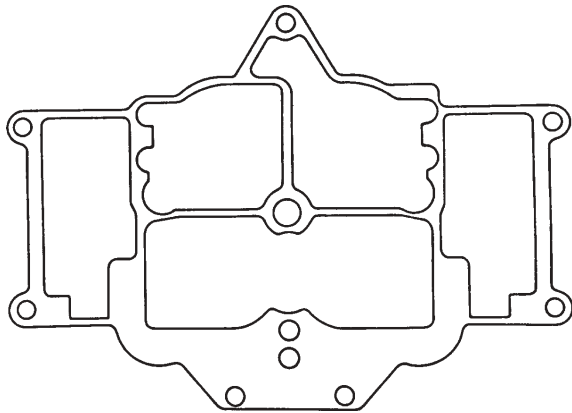

**MAZDA (Rotary) (4 cyl).....1974-72**

 <p><b>62-57</b> "E" CLIP RETAINER</p>	 <p><b>32-55</b> COTTER PIN</p>	 <p><b>G1158</b> PUMP DISCHARGE NOZZLE WASHER</p>	 <p><b>G57</b> FIBER JET WASHER</p>	 <p><b>G38</b> NEEDLE SEAT WASHER</p>	 <p><b>G59</b> FUEL INLET WASHER</p>	 <p><b>2F</b> NEEDLE SEAT WASHER</p>
---	--	--	--	---	---	---

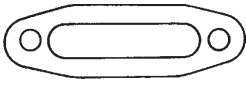
 <p><b>397F</b> INLET FITTING WASHER</p>	 <p><b>11F</b> BANJO UNION BOLT WASHER</p>	 <p><b>74F</b> UPPER INLET BANJO WASHER</p>	 <p><b>G49</b> FIBER VALVE WASHER</p>	 <p><b>708F</b> FLOAT BOWL WINDOW O-RING</p>	 <p><b>632F</b> PUMP DISCHARGE NOZZLE GASKET</p>
---	---	--	---	---	---

 <p><b>631F</b> SEC. DIAPHRAGM MOUNTING GASKET</p>	 <p><b>630F</b> SOLENOID VALVE GASKET</p>	 <p><b>627F</b> BOWL COVER GASKET</p>
 <p><b>633F</b> FLOAT BOWL WINDOW GASKET</p>	 <p><b>348F</b> CORK PRESSURE REGULATOR GASKET</p>	

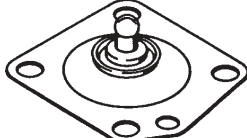
 <p><b>628F</b> THROTTLE BODY GASKET</p>	 <p><b>629F</b> THROTTLE BODY GASKET</p>	 <p><b>320F</b> FLANGE GASKET</p>
---	--	--

 <p><b>751F</b> AUXILIARY DIAPHRAGM ASSEMBLY</p>	 <p><b>752F</b> PUMP DIAPHRAGM ASSEMBLY</p>	 <p><b>31-590</b> NEEDLE &amp; SEAT ASSEMBLY</p>
---	---	---







**REFERENCE**





**WALKER CARBURETOR  
KIT #15613**

# NIKKI

**"APPLICATION"**

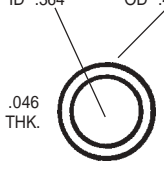
**MAZDA (4 cyl).....1974-72**

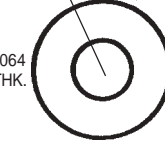
 <p><b>90-21</b> CHECK BALL 1/8" STEEL</p>	 <p><b>62-56</b> ROD RETAINER</p>	 <p><b>32-10</b> COTTER PIN</p>	 <p>ID .194 OD .293 .020 THK.</p> <p><b>610F</b> ALUM. MAIN JET WASHER</p>	 <p>ID .234 OD .376 .032 THK.</p> <p><b>G57</b> FIBER JET WASHER</p>	 <p>ID .325 OD .417 .020 THK.</p> <p><b>640F</b> THROTTLE BODY PLUG WASHER</p>	 <p>ID .315 OD .411 .032 THK.</p> <p><b>G59</b> FUEL INLET WASHER</p>
---	--	--	---	---	---	--

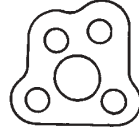
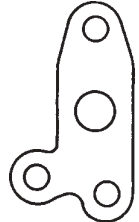
 <p>ID .364 OD .498 .046 THK.</p> <p><b>608F</b> STARTER PETROL JET WASHER</p>	 <p>ID .542 OD .673 .038 THK.</p> <p><b>609F</b> ALUM. BANJO BOLT WASHER</p>	 <p>ID .312 OD .702 .064 THK.</p> <p><b>74F</b> UPPER INLET BANJO WASHER</p>	 <p><b>347F</b> SEC. VENTURI GASKET</p>	 <p><b>612F</b> SEC. DIAPHRAGM MOUNTING GASKET</p>	 <p><b>611F</b> SOLENOID VALVE GASKET</p>
--	---	---	--	---	--

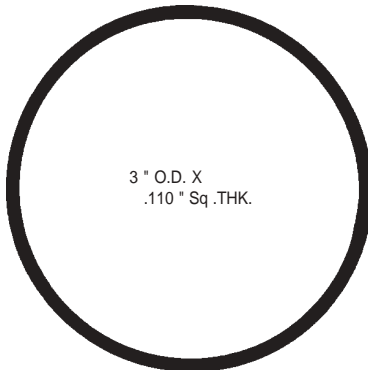
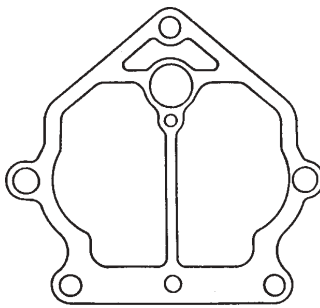
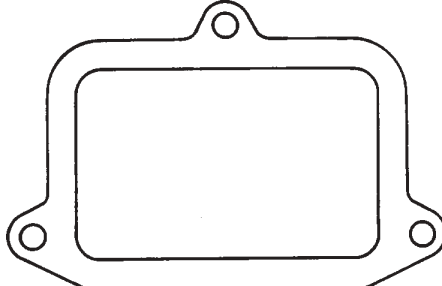
 <p>3" O.D. X .110" Sq. THK.</p> <p><b>704F</b> FUEL WINDOW SEAL</p>	 <p><b>336F</b> AIR HORN GASKET</p>	 <p><b>338F</b> FUEL WINDOW CLAMP GASKET</p>
---	---	---

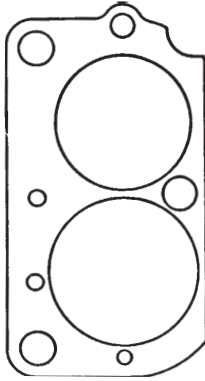
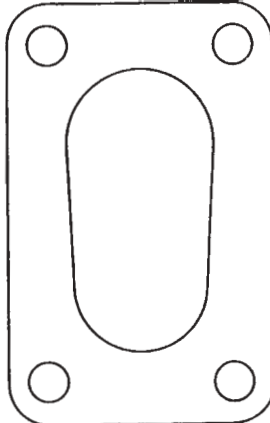
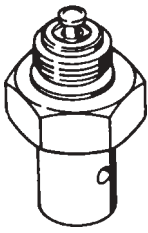
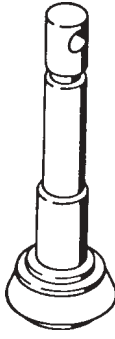
 <p><b>337F</b> THROTTLE BODY GASKET</p>	 <p><b>486F</b> FLANGE GASKET</p>	 <p><b>31-609</b> NEEDLE &amp; SEAT ASSEMBLY</p>	 <p><b>754F</b> PUMP PLUNGER ASSEMBLY</p>
---	--	---	--









**REFERENCE**

**WALKER CARBURETOR  
KIT #15649A**

**NIKKI**

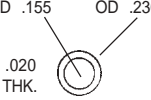
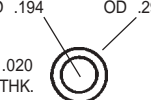
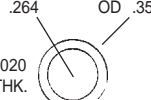
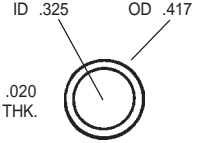
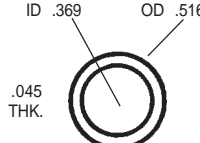
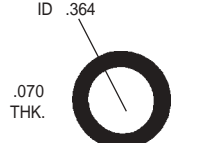
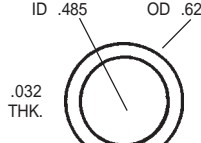
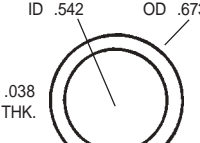
**"APPLICATION"**

**OPEL (4 cyl).....1979-76**

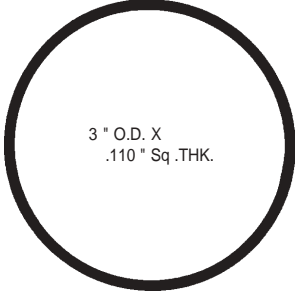
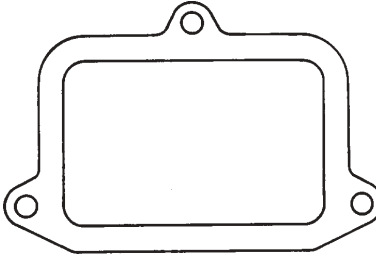
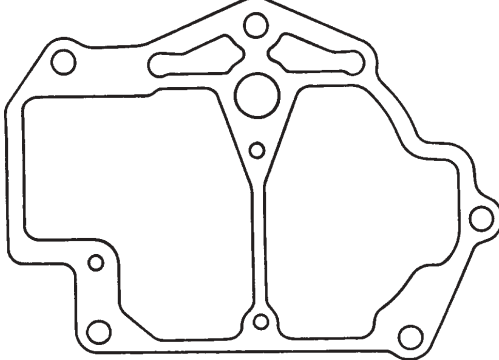
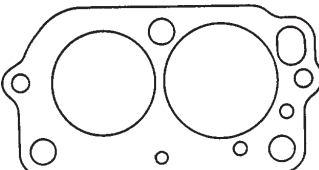
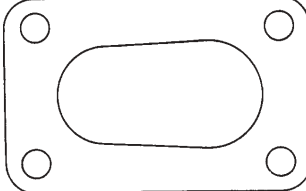
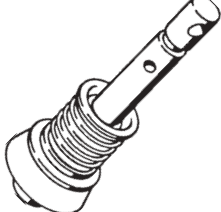
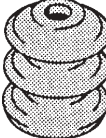
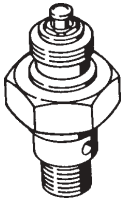
 <p><b>90-21</b> <b>CHECK BALL</b> <b>1/8\"</b></p>	 <p><b>62-56</b> <b>ROD</b> <b>RETAINER</b></p>	 <p><b>62-85</b> <b>ROD</b> <b>RETAINER</b></p>	 <p><b>32-10</b> <b>COTTER</b> <b>PIN</b></p>	 <p><b>971F</b> <b>NEEDLE SEAT</b> <b>WASHER</b></p>	 <p><b>610F</b> <b>ALUM. MAIN</b> <b>JET WASHER</b></p>	 <p><b>1183F</b> <b>IDLE NOZZLE</b> <b>PLUG WASHER</b></p>
 <p><b>640F</b> <b>THROTTLE BODY</b> <b>PLUG WASHER</b></p>	 <p><b>2F</b> <b>NEEDLE SEAT</b> <b>WASHER</b></p>	 <p><b>G275</b> <b>FUEL VALVE</b> <b>SEAT SEAL</b></p>	 <p><b>215F</b> <b>FUEL VALVE</b> <b>SEAT WASHER</b></p>	 <p><b>609F</b> <b>ALUM. BANJO</b> <b>BOLT WASHER</b></p>		
 <p><b>617F</b> <b>VENTURI CLUSTER</b> <b>GASKET</b></p>	 <p><b>615F</b> <b>SEC. DIAPHRAGM</b> <b>MOUNTING GASKET</b></p>	 <p><b>618F</b> <b>CHOKE HOUSING</b> <b>MOUNTING GASKET</b></p>	 <p><b>616F</b> <b>IDLE SOLENOID</b> <b>GASKET</b></p>	 <p><b>704F</b> <b>FUEL WINDOW</b> <b>SEAL</b></p>		
 <p><b>338F</b> <b>FUEL WINDOW</b> <b>CLAMP GASKET</b></p>	 <p><b>613F</b> <b>AIR HORN</b> <b>GASKET</b></p>	 <p><b>614F</b> <b>THROTTLE BODY</b> <b>GASKET</b></p>				
 <p><b>486F</b> <b>FLANGE GASKET</b></p>	 <p><b>763F</b> <b>PUMP PLUNGER</b> <b>ASSEMBLY</b></p>	 <p><b>542F</b> <b>PUMP PLUNGER</b> <b>BOOT</b></p>	 <p><b>31-615</b> <b>NEEDLE &amp; SEAT</b> <b>ASSEMBLY</b></p>			







**REFERENCE**

**WALKER CARBURETOR  
KIT #15739B**

# NIKKI

**"APPLICATION"**

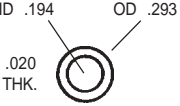
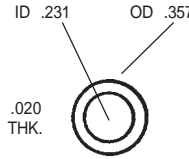
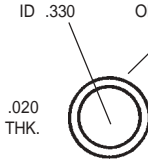
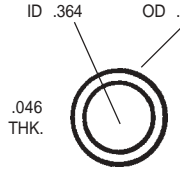
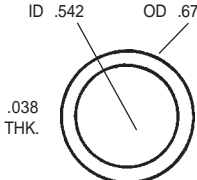
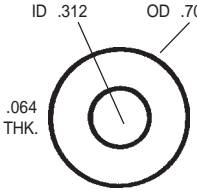
**COURIER (4 cyl).....1982-79  
MAZDA (4 cyl).....1984-79**

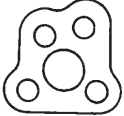
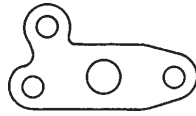
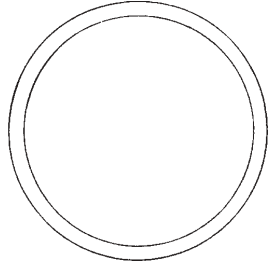
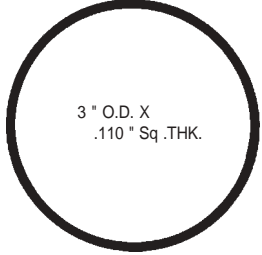
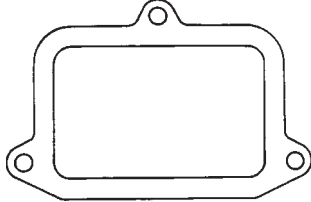
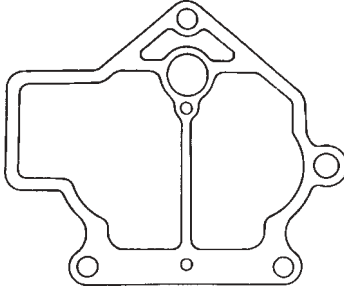
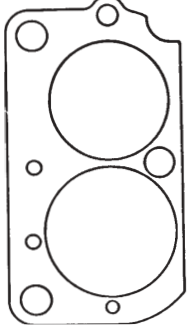
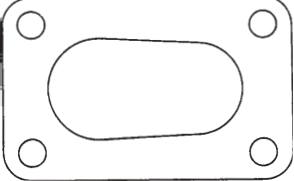
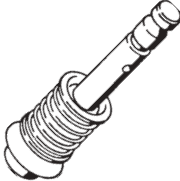
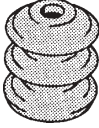
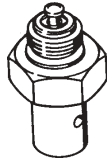
 <p><b>90-21</b> CHECK BALL 1/8" STEEL</p>	 <p><b>62-56</b> ROD RETAINER</p>	 <p><b>62-57</b> "E" CLIP RETAINER</p>	 <p><b>62-45</b> "E" CLIP RETAINER</p>	 <p><b>32-10</b> COTTER PIN</p>	 <p>ID .194 OD .293 .020 THK.</p> <p><b>610F</b> ALUM. MAIN JET WASHER</p>
 <p>ID .231 OD .357 .020 THK.</p> <p><b>244F</b> COPPER PUMP NOZZLE WASHER</p>	 <p>ID .330 OD .415 .020 THK.</p> <p><b>1057F</b> ALUM. NEEDLE SEAT WASHER</p>	 <p>ID .364 OD .498 .046 THK.</p> <p><b>608F</b> STARTER PETROL JET WASHER</p>	 <p>ID .542 OD .673 .038 THK.</p> <p><b>609F</b> ALUM. BANJO BOLT WASHER</p>	 <p>ID .312 OD .702 .064 THK.</p> <p><b>74F</b> UPPER INLET BANJO WASHER</p>	
 <p><b>786F</b> VENTURI CLUSTER GASKET</p>	 <p><b>612F</b> SECONDARY DIAPHRAGM MOUNTING GASKET</p>	 <p><b>611F</b> SOLENOID VALVE GASKET</p>	 <p><b>G97-1</b> THERMOSTATIC HOUSING GASKET</p>		
 <p>3" O.D. X .110" Sq. THK.</p> <p><b>704F</b> FUEL WINDOW SEAL</p>	 <p><b>338F</b> FUEL WINDOW CLAMP GASKET</p>	 <p><b>642F</b> AIR HORN GASKET</p>	 <p><b>337F</b> THROTTLE BODY GASKET</p>		
 <p><b>486F</b> FLANGE GASKET</p>	 <p><b>766F</b> PUMP PLUNGER ASSEMBLY</p>	 <p><b>542F</b> PUMP PLUNGER BOOT</p>	 <p><b>31-619</b> NEEDLE &amp; SEAT ASSEMBLY</p>		



**REFERENCE**

**WALKER CARBURETOR  
KIT #15781B**



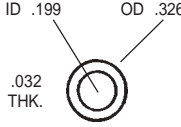
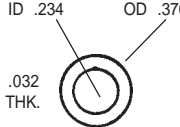
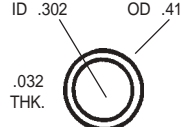
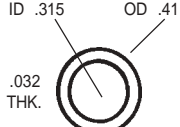

**NIKKI**

**"APPLICATION"**

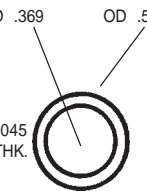
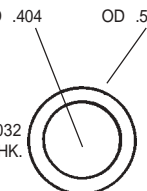
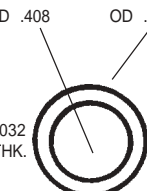
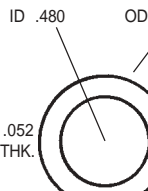
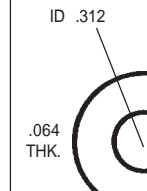
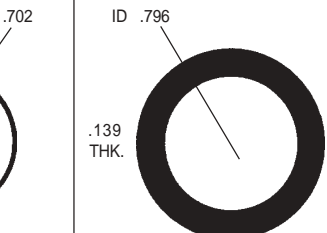

**MAZDA (Rotary) (4 cyl).....1984-79**

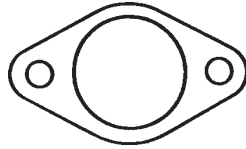
 <p><b>62-57</b> "E" CLIP RETAINER</p>	 <p><b>32-55</b> COTTER PIN</p>	 <p><b>G1158</b> PUMP DISCHARGE NOZZLE WASHER</p>	 <p><b>G57</b> FIBER JET WASHER</p>	 <p><b>G38</b> NEEDLE SEAT WASHER</p>	 <p><b>G59</b> FUEL INLET WASHER</p>
---	--	--	---	--	---

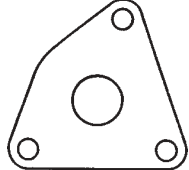
 <p><b>2F</b> NEEDLE SEAT WASHER</p>	 <p><b>397F</b> INLET FITTING WASHER</p>	 <p><b>245F</b> MAIN JET PLUG GASKET</p>	 <p><b>963F</b> BANJO ALUMINUM WASHER</p>	 <p><b>74F</b> UPPER INLET BANJO WASHER</p>	 <p><b>708F</b> FLOAT BOWL WINDOW O-RING</p>
---	---	---	--	---	---

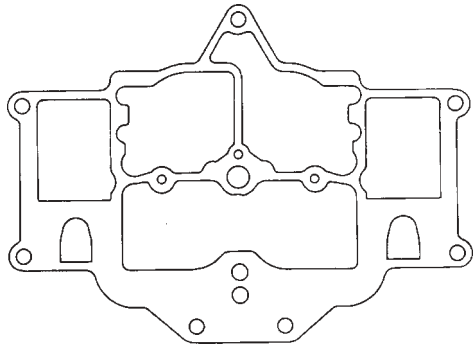
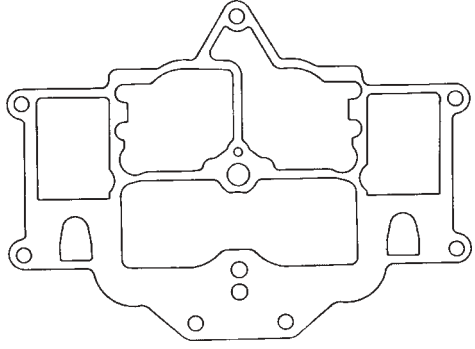
 <p><b>632F</b> PUMP DISCHARGE NOZZLE GASKET</p>	 <p><b>631F</b> SEC. DIAPHRAGM MOUNTING GASKET</p>	 <p><b>630F</b> SOLENOID VALVE GASKET</p>	 <p><b>633F</b> FLOAT BOWL WINDOW GASKET</p>	 <p><b>740F</b> VENT VALVE GASKET</p>
---	---	--	---	--

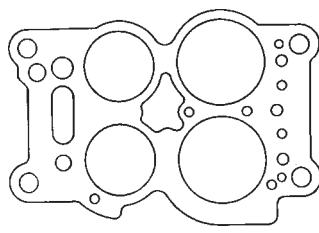
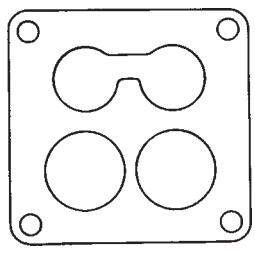
 <p><b>780F</b> BOWL COVER GASKET</p>	 <p><b>781F</b> BOWL COVER GASKET</p>
--	---

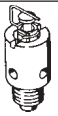
 <p><b>960F</b> THROTTLE BODY GASKET</p>	 <p><b>320F</b> FLANGE GASKET</p>	 <p><b>751F</b> PUMP DIAPHRAGM ASSEMBLY</p> <hr/>  <p><b>31-626</b> NEEDLE &amp; SEAT ASSEMBLY</p>
---	---	--











**REFERENCE**

**WALKER CARBURETOR  
KIT #15785**

**NIKKI**

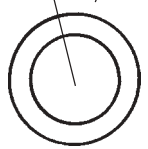
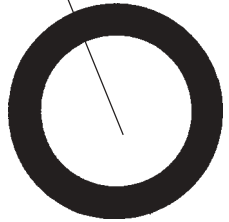
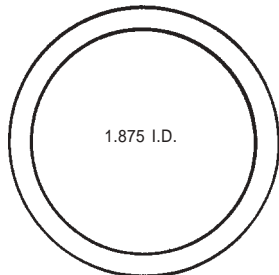
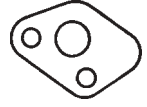
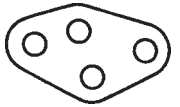
**"APPLICATION"**

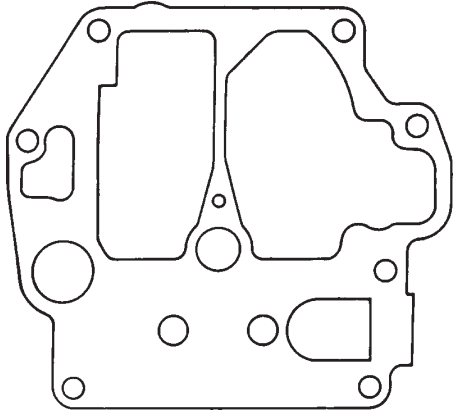
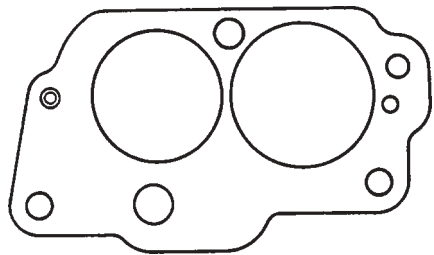
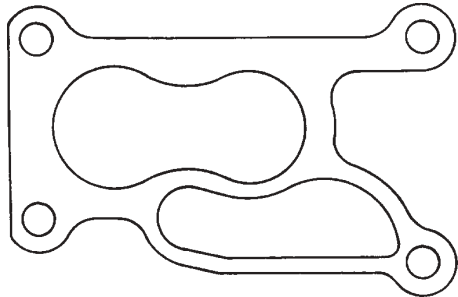
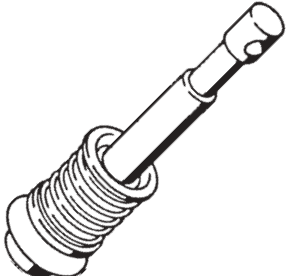
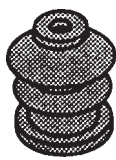
**MAZDA (4 cyl).....1981-79**

 <p><b>90-21</b> CHECK BALL 1/8" STEEL</p>	 <p><b>62-96</b> "E" CLIP RETAINER</p>	 <p><b>62-45</b> "E" CLIP RETAINER</p>	 <p><b>32-55</b> COTTER PIN</p>	 <p>ID .194 OD .293 .020 THK.</p> <p><b>610F</b> ALUM. MAIN JET WASHER</p>	 <p>ID .330 OD .415 .020 THK.</p> <p><b>1057F</b> ALUM. NEEDLE SEAT WASHER</p>
 <p>ID .480 OD .661 .052 THK.</p> <p><b>963F</b> BANJO ALUMINUM WASHER</p>	 <p>ID .796 .139 THK.</p> <p><b>708F</b> FLOAT BOWL WINDOW O-RING</p>	 <p>1.875 I.D.</p> <p><b>243F</b> COIL HOUSING GASKET</p>	 <p><b>965F</b> VENTURI CLUSTER GASKET</p> <hr/>  <p><b>964F</b> SEC. DIAPHRAGM MOUNTING GASKET</p>		
 <p><b>633F</b> FLOAT BOWL WINDOW GASKET</p>	 <p><b>962F</b> BOWL COVER GASKET</p>	 <p><b>966F</b> THROTTLE BODY GASKET</p>			
 <p><b>1051F</b> FLANGE GASKET</p>	 <p><b>767F</b> PUMP PLUNGER ASSEMBLY</p>	 <p><b>543F</b> PUMP PLUNGER BOOT</p>	 <p><b>967F</b> VENTURI TUBE GASKET</p> <hr/>  <p><b>31-648</b> NEEDLE &amp; SEAT ASSEMBLY</p>		

**REFERENCE**

**WALKER CARBURETOR  
KIT #15839**

**NIKKI**

**"APPLICATION"**

**MAZDA (4 cyl).....1982-81**



**90-21  
CHECK BALL  
1/8" STEEL**



**62-96  
"E" CLIP  
RETAINER**



**62-45  
"E" CLIP  
RETAINER**



**32-55  
COTTER PIN**

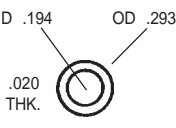

ID .194 OD .293  
.020 THK.

**610F  
ALUM. MAIN  
JET WASHER**

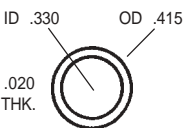

ID .330 OD .415  
.020 THK.

**1057F  
ALUM. NEEDLE  
SEAT WASHER**

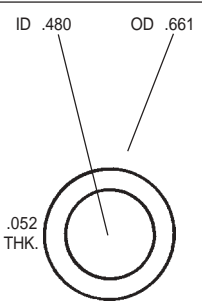

ID .480 OD .661  
.052 THK.

**963F  
BANJO ALUMINUM  
WASHER**

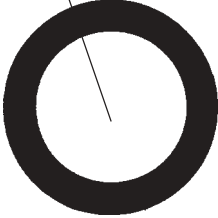

ID .796  
.139 THK.

**708F  
FLOAT BOWL  
WINDOW O-RING**

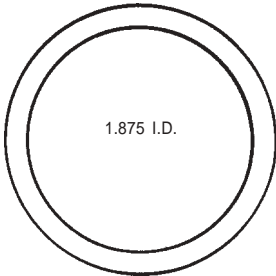

1.875 I.D.

**243F  
COIL HOUSING  
GASKET**



**633F  
FLOAT BOWL  
WINDOW GASKET**



**965F  
VENTURI CLUSTER  
GASKET**



**964F  
SEC. DIAPHRAGM  
MOUNTING GASKET**

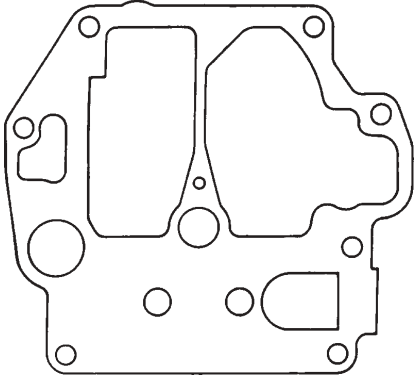

**962F  
BOWL COVER  
GASKET**

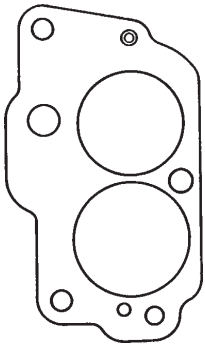

**966F  
THROTTLE BODY  
GASKET**

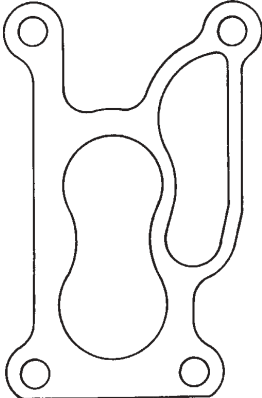

**1051F  
FLANGE GASKET**

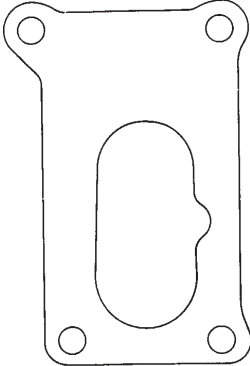

**968F  
FLANGE GASKET**

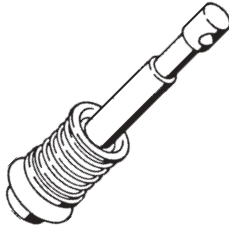

**767F  
PUMP PLUNGER  
ASSEMBLY**



**543F  
PUMP PLUNGER  
BOOT**



**967F  
VENTURI TUBE  
GASKET**



**31-627  
NEEDLE & SEAT  
ASSEMBLY**















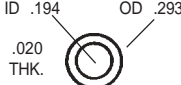



**REFERENCE**

**WALKER CARBURETOR  
KIT #151018A**

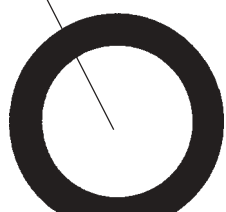
**NIKKI**

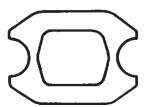
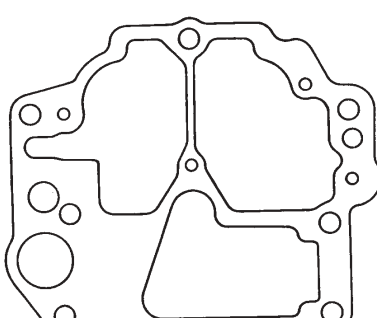
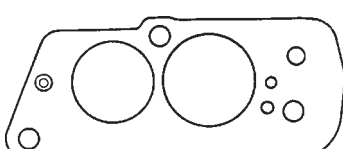
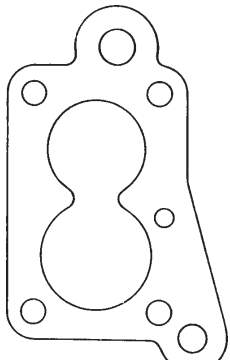
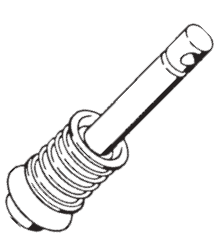
**"APPLICATION"**

**CHEVROLET (4 cyl).....1989-85  
ISUZU (4 cyl).....1989-85**

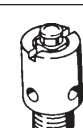
 <p><b>90-21</b> CHECK BALL 1/8" STEEL</p>	 <p><b>90-12</b> CHECK BALL 5/32" STEEL</p>	 <p><b>62-57</b> "E" CLIP RETAINER</p>	 <p><b>62-45</b> "E" CLIP RETAINER</p>	 <p><b>62-93</b> "E" CLIP RETAINER</p>	 <p>ID .194 OD .293 .020 THK.</p> <p><b>610F</b> ALUM. MAIN JET WASHER</p>
 <p>ID .187 OD .312 .032 THK.</p> <p><b>G495</b> RUBBER CHOKE HOUSING WASHER</p>	 <p>ID .176 .070 THK.</p> <p><b>G273</b> SEC. CONNECTING TUBE SEAL</p>	 <p>ID .208 .070 THK.</p> <p><b>G935</b> PUMP DISCHARGE NOZZLE O-RING</p>	 <p>ID .276 .059 THK.</p> <p><b>1007F</b> LOWER FEEDBACK O-RING</p>	 <p>ID .369 OD .516 .045 THK.</p> <p><b>2F</b> NEEDLE SEAT WASHER</p>	
 <p>ID .354 .059 THK.</p> <p><b>1006F</b> UPPER FEEDBACK O-RING</p>	 <p>ID .480 OD .661 .052 THK.</p> <p><b>963F</b> BANJO ALUMINUM WASHER</p>	 <p>ID .796 .139 THK.</p> <p><b>708F</b> FLOAT BOWL WINDOW O-RING</p>	 <p><b>1112F</b> VENTURI CLUSTER GASKET</p>	 <p><b>1142F</b> PRIMARY VENTURY GASKET</p>	
 <p><b>1106F</b> BOWL WINDOW GASKET</p>	 <p><b>1110F</b> BOWL COVER GASKET</p>	 <p><b>1173F</b> THROTTLE BODY GASKET</p>			
 <p><b>1111F</b> FLANGE GASKET</p>	 <p><b>1158F</b> PUMP PLUNGER ASSEMBLY</p>	 <p><b>907F</b> CHOKE COVER POP RIVET</p>	 <p><b>543F</b> PUMP PLUNGER BOOT</p>	 <p><b>967F</b> VENTURI TUBE GASKET</p> <hr/>  <p><b>31-671</b> NEEDLE &amp; SEAT ASSEMBLY</p>	









**REFERENCE**





**WALKER CARBURETOR  
KIT #151048**





**NIKKI**

**"APPLICATION"**

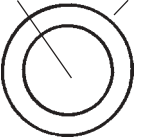

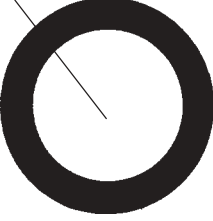

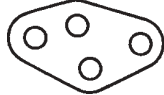
**MAZDA (4 cyl).....1989-86**

 <p><b>90-21</b> CHECK BALL 1/8" STEEL</p>	 <p><b>62-42</b> "E" CLIP RETAINER</p>	 <p><b>62-45</b> "E" CLIP RETAINER</p>	 <p><b>32-55</b> COTTER PIN</p>	 <p><b>G495</b> RUBBER CHOKE HOUSING WASHER</p> <p>ID .187 OD .312 .032 THK.</p>	 <p><b>G1266</b> HOT AIR PASSAGE GASKET</p> <p>ID .215 OD .320 .062 THK.</p>
---	---	---	---	---	---

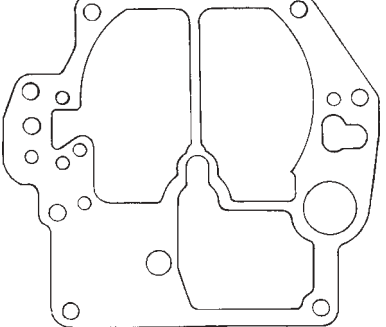
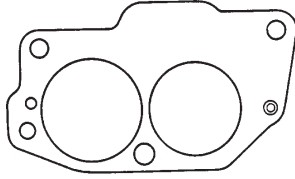
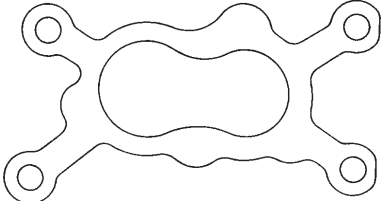
 <p><b>1007F</b> LOWER FEEDBACK O-RING</p> <p>ID .276 .059 THK.</p>	 <p><b>1057F</b> ALUM. NEEDLE SEAT WASHER</p> <p>ID .330 OD .415 .020 THK.</p>	 <p><b>1006F</b> UPPER FEEDBACK O-RING</p> <p>ID .354 .059 THK.</p>	 <p><b>847F</b> FLOAT CHAMBER PLUG O-RING</p> <p>ID .426 .065 THK.</p>	 <p><b>963F</b> BANJO ALUMINUM WASHER</p> <p>ID .480 OD .661 .052 THK.</p>
--	---	--	---	---

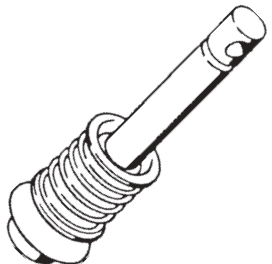
 <p><b>708F</b> FLOAT BOWL WINDOW O-RING</p> <p>ID .796 .139 THK.</p>	 <p><b>1117F</b> VENTURI CLUSTER GASKET</p>	 <p><b>964F</b> SECONDARY DIAPHRAGM MOUNTING GASKET</p>	 <p><b>633F</b> FLOAT BOWL WINDOW GASKET</p>
--	--	---	---

 <p><b>1135F</b> BOWL COVER GASKET</p>	 <p><b>1082F</b> THROTTLE BODY INSULATOR ASSEMBLY</p>	 <p><b>1083F</b> FLANGE GASKET</p>
---	---	---

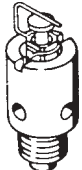
 <p><b>1158F</b> PUMP PLUNGER ASSEMBLY</p>	 <p><b>907F</b> CHOKE COVER POP RIVET</p>	 <p><b>477F</b> PUMP PLUNGER BOOT</p>	 <p><b>967F</b> VENTURI TUBE SEAL</p>	 <p><b>31-667</b> NEEDLE &amp; SEAT ASSEMBLY</p>
---	--	---	--	---















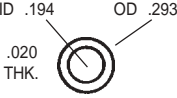

**REFERENCE**

**WALKER CARBURETOR  
KIT #151083**

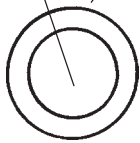
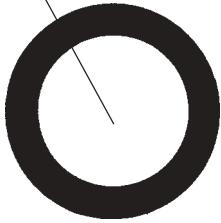
# NIKKI

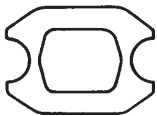
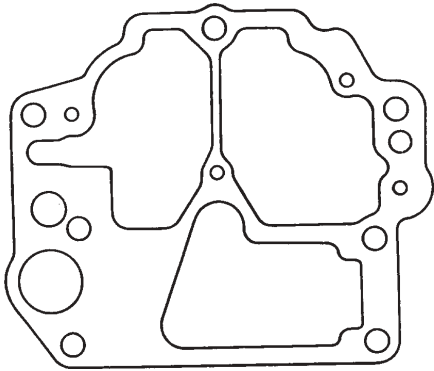
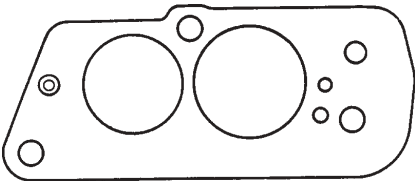
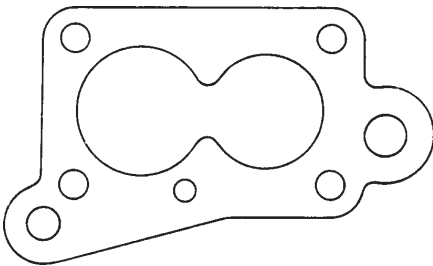
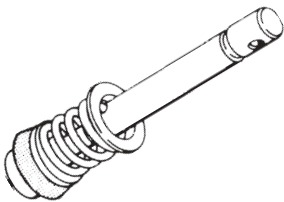
**"APPLICATION"**

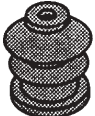
**CHEVROLET (4 cyl).....1989-85**

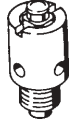
 <p><b>90-21</b> CHECK BALL 1/8" STEEL</p>	 <p><b>90-12</b> CHECK BALL 5/32" STEEL</p>	 <p><b>62-57</b> "E" CLIP RETAINER</p>	 <p><b>62-45</b> "E" CLIP RETAINER</p>	 <p><b>62-93</b> "E" CLIP RETAINER</p>	 <p>ID .194 OD .293 .020 THK.</p> <p><b>610F</b> ALUM. MAIN JET WASHER</p>
 <p>ID .176 .070 THK.</p> <p><b>G273</b> SEC. CONNECTING TUBE SEAL</p>	 <p>ID .187 OD .312 .032 THK.</p> <p><b>G495</b> RUBBER CHOKE HOUSING WASHER</p>	 <p>ID .208 .070 THK.</p> <p><b>G935</b> PUMP DISCHARGE NOZZLE O-RING</p>	 <p>ID .276 .059 THK.</p> <p><b>1007F</b> LOWER FEEDBACK O-RING</p>	 <p>ID .354 .059 THK.</p> <p><b>1006F</b> UPPER FEEDBACK O-RING</p>	
 <p>ID .369 OD .516 .045 THK.</p> <p><b>2F</b> NEEDLE SEAT WASHER</p>	 <p>ID .480 OD .661 .052 THK.</p> <p><b>963F</b> BANJO ALUMINUM WASHER</p>	 <p>ID .796 .139 THK.</p> <p><b>708F</b> FLOAT BOWL WINDOW O-RING</p>	 <p><b>1112F</b> VENTURI CLUSTER GASKET</p>	 <p><b>1142F</b> PRIMARY VENTURY GASKET</p>	
 <p><b>1106F</b> BOWL WINDOW GASKET</p>	 <p><b>1110F</b> BOWL COVER GASKET</p>	 <p><b>1173F</b> THROTTLE BODY GASKET</p>			
 <p><b>1111F</b> FLANGE GASKET</p>	 <p><b>1233F</b> PUMP PLUNGER ASSEMBLY</p>	 <p><b>907F</b> CHOKE COVER POP RIVET</p>	 <p><b>543F</b> PUMP PLUNGER BOOT</p>	 <p><b>967F</b> VENTURI TUBE SEAL</p>  <p><b>31-671</b> NEEDLE &amp; SEAT ASSEMBLY</p>	









**REFERENCE**

**WALKER CARBURETOR  
KIT #151100A**

**NIKKI**

**"APPLICATION"**

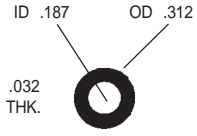
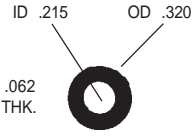
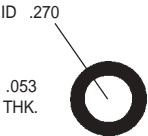
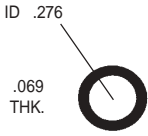
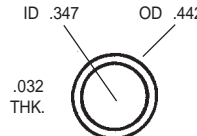
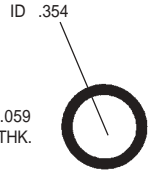
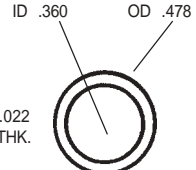
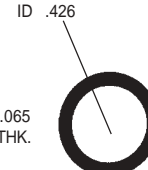
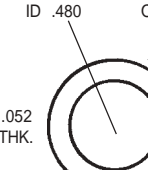
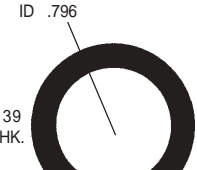
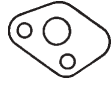
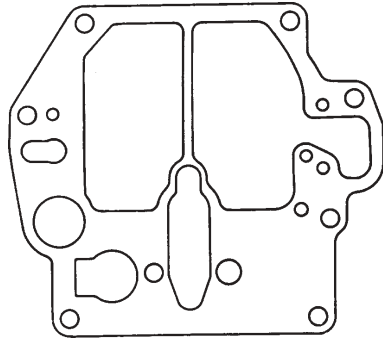
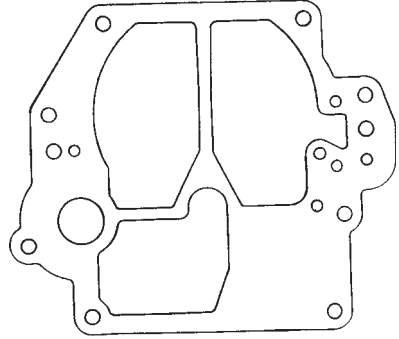
**MAZDA (4 cyl).....1991-83**

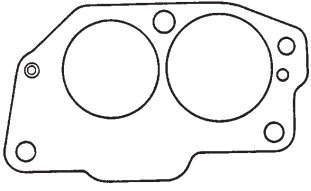
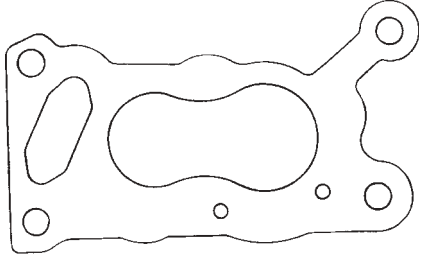
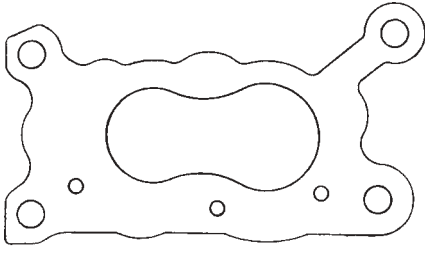
 <p><b>90-21 PUMP INLET BALL 1/8" STEEL</b></p>	 <p><b>62-57 "E" CLIP RETAINER</b></p>	 <p><b>62-42 "E" CLIP RETAINER</b></p>	 <p><b>62-63 "E" CLIP RETAINER</b></p>	 <p><b>62-45 "E" CLIP RETAINER</b></p>	 <p><b>32-55 COTTER PIN</b></p>
 <p><b>G495 RUBBER CHOKE HOUSING WASHER</b></p>	 <p><b>G1266 HOT AIR PASSAGE GASKET</b></p>	 <p><b>775F O-RING</b></p>	 <p><b>1007F LOWER FEEDBACK O-RING</b></p>	 <p><b>G405 POWER VALVE GASKET</b></p>	
 <p><b>1006F UPPER FEEDBACK O-RING</b></p>	 <p><b>1271F NEEDLE SEAT GASKET</b></p>	 <p><b>847F FLOAT CHAMBER PLUG O-RING</b></p>	 <p><b>963F BANJO ALUMINUM WASHER</b></p>	 <p><b>708F FLOAT BOWL WINDOW O-RING</b></p>	
 <p><b>965F VENTURI CLUSTER GASKET</b></p>	 <p><b>1081F BOWL COVER GASKET</b></p>		 <p><b>1272F BOWL COVER GASKET</b></p>		
 <p><b>1117F VENTURI CLUSTER GASKET</b></p>					
 <p><b>1082F THROTTLE BODY INSULATOR ASSEMBLY</b></p>	 <p><b>1273F FLANGE GASKET</b></p>	 <p><b>1274F FLANGE GASKET</b></p>			

**REFERENCE**

**WALKER CARBURETOR  
KIT #151100A**

# NIKKI

**"APPLICATION"**

**MAZDA (4 cyl).....1991-83**

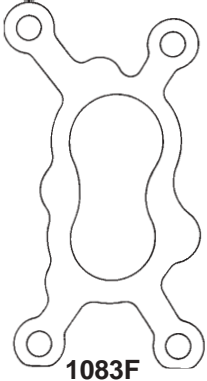

**1083F  
FLANGE GASKET**



**907F  
CHOKE COVER  
POP RIVET**

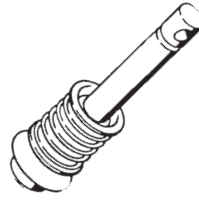

**1153F  
PUMP PLUNGER  
ASSEMBLY**



**477F  
PUMP PLUNGER  
BOOT**



**1275F  
PUMP BOOT**



**967F  
VENTURITUBE  
SEAL**



**31-667  
NEEDLE & SEAT  
ASSEMBLY**