









**REFERENCE**







**WALKER CARBURETOR  
KIT #15474B**

# HITACHI

**"APPLICATION"**

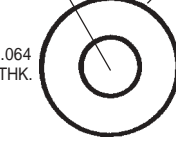

**NISSAN (4 cyl).....1974-68**

 <b>90-12</b> CHECK BALL 5/32" STEEL	 <b>62-56</b> ROD RETAINER	 <b>62-57</b> "E" CLIP RETAINER	 <b>62-64</b> PUMP RETAINER	 ID .174 OD .310 .032 THK. <b>G365</b> STEP-UP JET WASHER	 ID .253 .032 THK. <b>G1141</b> NEEDLE SEAT WASHER	 ID .315 OD .411 .032 THK. <b>G59</b> FUEL INLET WASHER	 ID .369 OD .517 .045 THK. <b>2F</b> NEEDLE SEAT WASHER
--	--	---	---	---	---	---	---

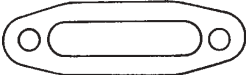
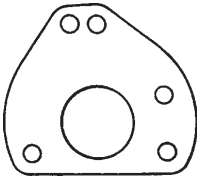
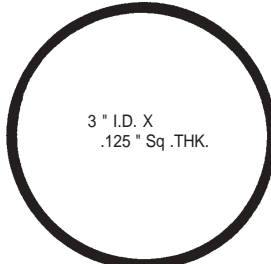
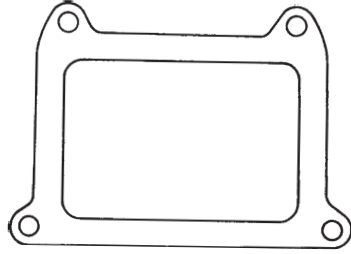
 ID .364 .070 THK. <b>G275</b> FUEL VALVE SEAT O-RING	 ID .484 OD .721 .032 THK. <b>11F</b> BANJO UNION BOLT WASHER	 ID .312 OD .702 .064 THK. <b>74F</b> UPPER INLET BANJO WASHER	 <b>347F</b> SEC. VENTURI GASKET	 <b>380F</b> PRI. VENTURI GASKET	 <b>349F</b> PUMP RETAINER GASKET	 <b>357F</b> SEC. DIAPHRAGM GASKET
---	---	--	---	--	---	--

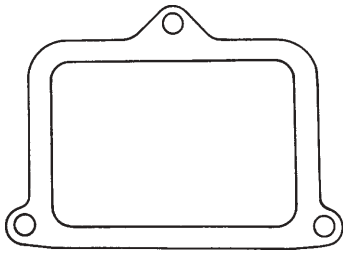
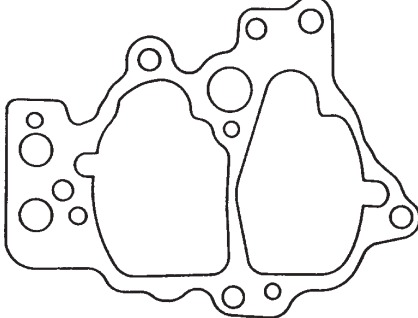
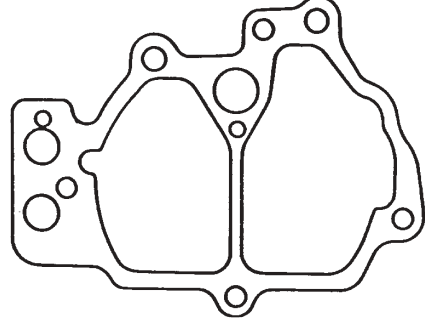
 <b>348F</b> CORK PRESSURE REGULATOR GASKET	 <b>362F</b> CONTROL UNIT GASKET	 3" I.D. X .125" Sq. THK. <b>333F</b> RUBBER FUEL WINDOW SEAL	 <b>331F</b> FUEL BOWL WINDOW GASKET
---	--	--	--

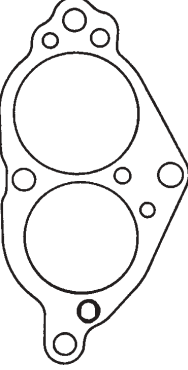
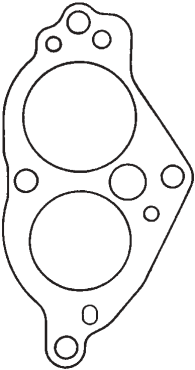
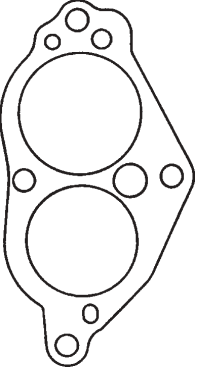
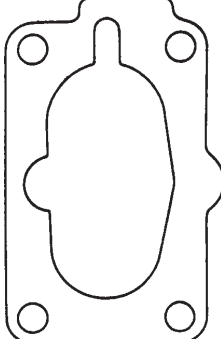
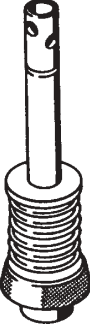
 <b>332F</b> FUEL BOWL WINDOW GASKET	 <b>317F</b> BOWL COVER GASKET	 <b>378F</b> BOWL COVER GASKET
--	---	--

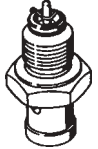
 <b>327F</b> THROTTLE BODY GASKET	 <b>329F</b> THROTTLE BODY GASKET	 <b>396F</b> THROTTLE BODY GASKET	 <b>310F</b> FLANGE GASKET	 <b>832F</b> PUMP PLUNGER ASSEMBLY	 <b>477F</b> PUMP PLUNGER BOOT
					 <b>31-209</b> NEEDLE & SEAT ASSEMBLY









**REFERENCE**

**WALKER CARBURETOR  
KIT #15526**

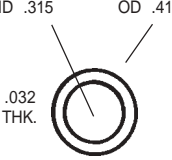
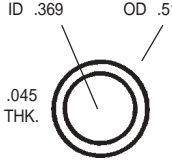
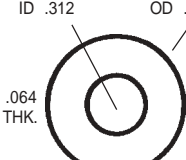
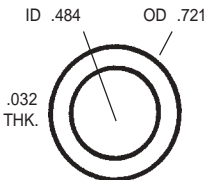
# HITACHI

**"APPLICATION"**

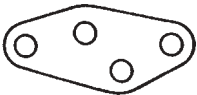
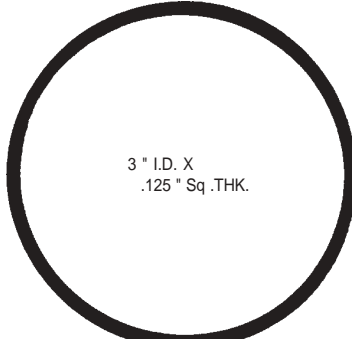
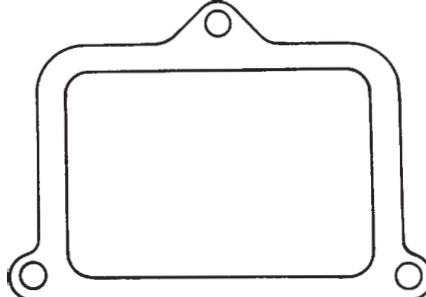
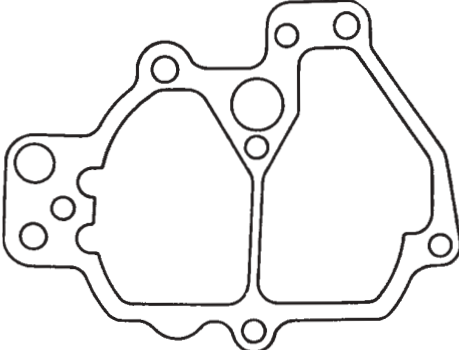
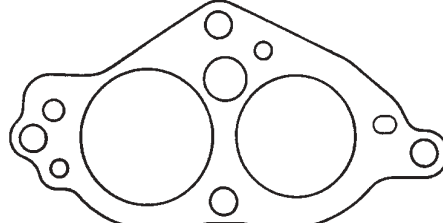
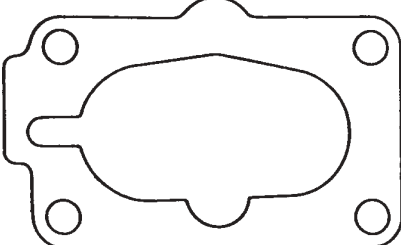
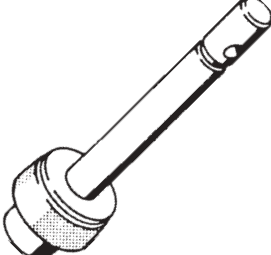
**COURIE (4 cyl).....1973-72  
MAZDA (4 cyl).....1972**

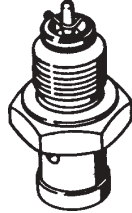
 <p><b>90-12</b> CHECK BALL 5/32" STEEL</p>	 <p><b>90-39</b> CHECK BALL 5/32" NYLON</p>	 <p><b>62-56</b> ROD RETAINER</p>	 <p>ID .315    OD .411 .032 THK.</p> <p><b>G59</b> FUEL INLET WASHER</p>	 <p>ID .369    OD .517 .045 THK.</p> <p><b>2F</b> NEEDLE SEAT WASHER</p>	 <p>ID .312    OD .702 .064 THK.</p> <p><b>74F</b> UPPER INLET BANJO WASHER</p>
 <p>ID .484    OD .721 .032 THK.</p> <p><b>11F</b> BANJO UNION BOLT WASHER</p>	 <p><b>347F</b> SEC. VENTURI GASKET</p>	 <p><b>380F</b> PRI. VENTURI GASKET</p>	 <p><b>349F</b> PUMP RETAINER GASKET</p>	 <p><b>357F</b> SEC. DIAPHRAGM GASKET</p>	
 <p>3" I.D. X .125" Sq. THK.</p> <p><b>333F</b> RUBBER FUEL WINDOW SEAL</p>	 <p><b>332F</b> FUEL BOWL WINDOW GASKET</p>	 <p><b>334F</b> BOWL COVER GASKET</p>			
 <p><b>329F</b> THROTTLE BODY GASKET</p>	 <p><b>310F</b> FLANGE GASKET</p>				
 <p><b>746F</b> PUMP PLUNGER ASSEMBLY</p>	 <p><b>477F</b> PUMP PLUNGER BOOT</p>	 <p><b>31-209</b> NEEDLE &amp; SEAT ASSEMBLY</p>			

**REFERENCE**  
**WALKER CARBURETOR**  
**KIT #15532B**

# HITACHI

**"APPLICATION"**  
**HONDA (4 cyl).....1976-73**  
**MAZDA (4 cyl).....1980-76**  
**NISSAN (4 cyl).....1981-70**



**90-12**  
**CHECK BALL**  
**5/32" STEEL**



**90-13**  
**CHECK BALL**  
**3/16" STEEL**



**32-11**  
**COTTER PIN**



**32-10**  
**COTTER PIN**

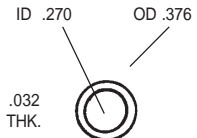

**G460**  
**RUBBER STEP-UP**  
**PISTON WASHER**

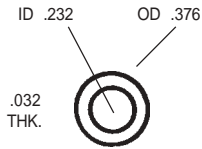

**G1240**  
**THROTTLE BODY**  
**SCREW WASHER**

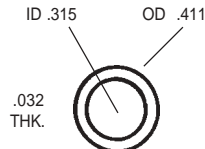

**G59**  
**FUEL INLET**  
**WASHER**

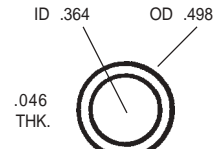

**608F**  
**MAIN JET**  
**WASHER**

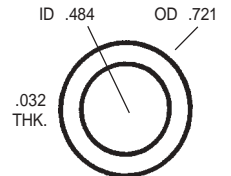

**11F**  
**BANJO UNION**  
**BOLT WASHER**

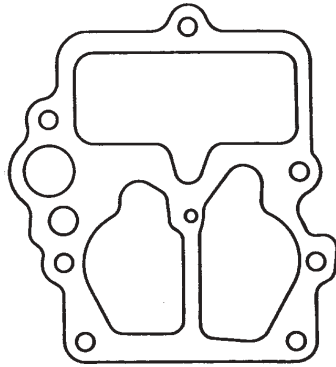

**949F** (3/64)  
**328F** (1/32)  
**BOWL COVER GASKET**

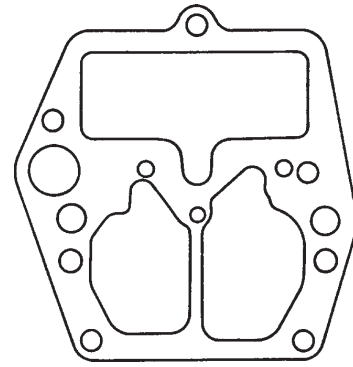

**452F**  
**BOWL COVER GASKET**

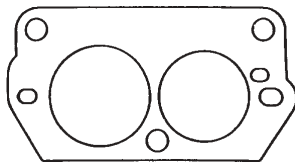

**514F**  
**THROTTLE BODY GASKET**

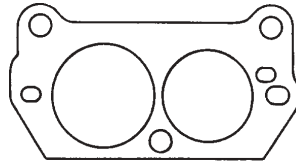

**818F**  
**THROTTLE BODY GASKET**

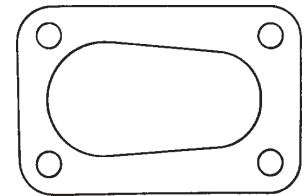

**414F**  
**FLANGE GASKET**

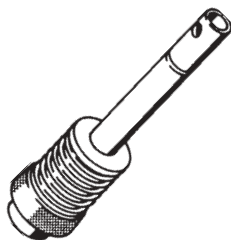

**505F**  
**PUMP PLUNGER**  
**ASSEMBLY**



**547F**  
**PUMP PLUNGER**  
**BOOT**



**31-206**  
**NEEDLE & SEAT**  
**ASSEMBLY**















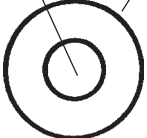
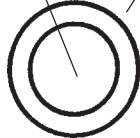

**REFERENCE**

**WALKER CARBURETOR  
KIT #15540B**

# HITACHI

**"APPLICATION"**

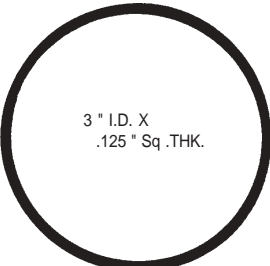
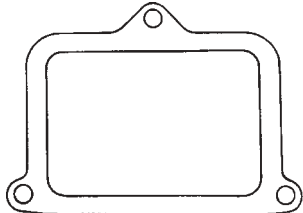
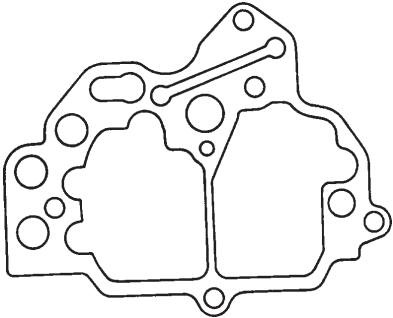
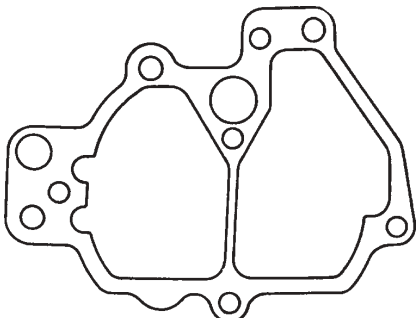
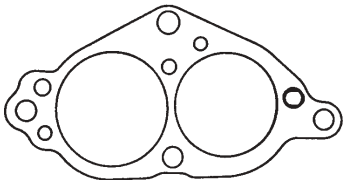
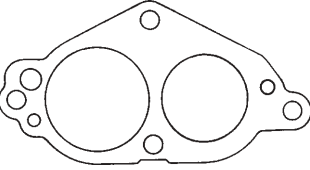
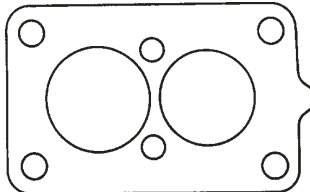
**LUV TRUCK (4 cyl).....1980-72**

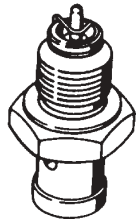
 <p><b>90-12</b> CHECK BALL 5/32" STEEL</p>	 <p><b>90-39</b> CHECK BALL 5/32" NYLON</p>	 <p><b>32-10</b> COTTER PIN</p>	 <p><b>62-64</b> PUMP RETAINER</p>	 <p>ID .174 OD .310 .032 THK.</p> <p><b>G365</b> STEP-UP JET WASHER</p>	 <p>ID .315 OD .411 .032 THK.</p> <p><b>G59</b> FUEL INLET WASHER</p>	 <p>ID .369 OD .517 .045 THK.</p> <p><b>2F</b> NEEDLE SEAT WASHER</p>
 <p>ID .476 .060 THK.</p> <p><b>685F</b> THROTTLE BYPASS VALVE O-RING</p>	 <p>ID .312 OD .702 .064 THK.</p> <p><b>74F</b> UPPER INLET BANJO WASHER</p>	 <p>ID .484 OD .721 .032 THK.</p> <p><b>11F</b> BANJO UNION BOLT WASHER</p>	 <p><b>347F</b> SEC. VENTURI GASKET</p>	 <p><b>380F</b> PRI. VENTURI GASKET</p>	 <p><b>394F</b> PRI. VENTURI GASKET</p>	
 <p><b>349F</b> PUMP RETAINER GASKET</p>	 <p><b>357F</b> SEC. DIAPHRAGM GASKET</p>	 <p>3" I.D. X .125" Sq .THK.</p> <p><b>333F</b> RUBBER FUEL WINDOW SEAL</p>	 <p><b>332F</b> FUEL BOWL WINDOW GASKET</p>			
 <p><b>511F</b> BOWL COVER GASKET</p>	 <p><b>334F</b> BOWL COVER GASKET</p>	 <p><b>327F</b> THROTTLE BODY GASKET</p>				
 <p><b>777F</b> THROTTLE BODY GASKET</p>	 <p><b>311F</b> FLANGE GASKET</p>	 <p><b>477F</b> PUMP PLUNGER BOOT</p>	 <p><b>31-213</b> NEEDLE &amp; SEAT ASSEMBLY</p>			







**REFERENCE**





**WALKER CARBURETOR  
KIT #15545**

# HITACHI

**"APPLICATION"**

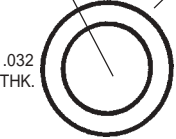
**COURIER (4 cyl)....1978-77,1974-73  
MAZDA (4 cyl).....1973**

 <p><b>90-12</b> CHECK BALL 5/32" STEEL</p>	 <p><b>90-39</b> CHECK BALL 5/32" NYLON</p>	 <p>ID .315 OD .411 .032 THK.</p> <p><b>G59</b> FUEL INLET WASHER</p>	 <p>ID .369 OD .517 .045 THK.</p> <p><b>2F</b> NEEDLE SEAT WASHER</p>	 <p>ID .364 .070 THK.</p> <p><b>G275</b> FUEL VALVE SEAT O-RING</p>	 <p>ID .312 OD .702 .064 THK.</p> <p><b>74F</b> UPPER INLET BANJO WASHER</p>
--	--	--	---	--	---

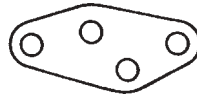
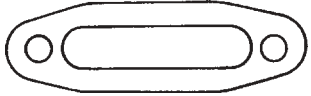
 <p>ID .484 OD .721 .032 THK.</p> <p><b>11F</b> BANJO UNION BOLT WASHER</p>	 <p><b>347F</b> SEC. VENTURI GASKET</p>	 <p><b>380F</b> PRI. VENTURI GASKET</p>	 <p><b>349F</b> PUMP RETAINER GASKET</p>	 <p><b>357F</b> SEC. DIAPHRAGM GASKET</p>	 <p><b>348F</b> CORK PRESSURE REGULATOR GASKET</p>
--	--	--	---	--	---

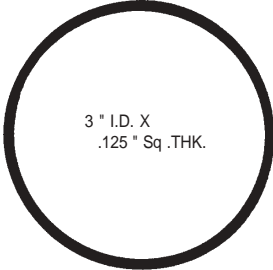
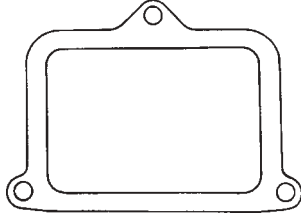
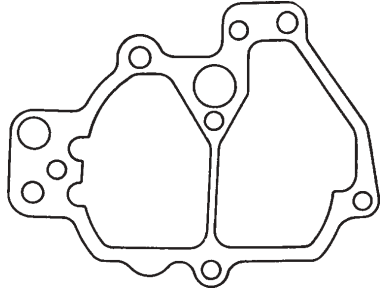
 <p>3" I.D. X .125" Sq .THK.</p> <p><b>333F</b> RUBBER FUEL WINDOW SEAL</p>	 <p><b>332F</b> FUEL BOWL WINDOW GASKET</p>	 <p><b>334F</b> BOWL COVER GASKET</p>
---	---	---

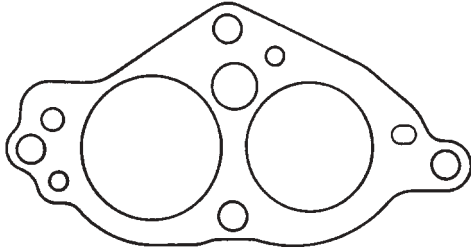
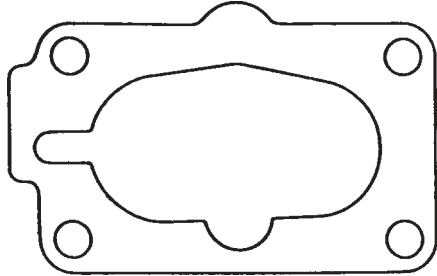
 <p><b>329F</b> THROTTLE BODY GASKET</p>	 <p><b>310F</b> FLANGE GASKET</p>
---	---

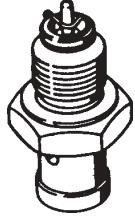
 <p><b>748F</b> PUMP PLUNGER ASSEMBLY</p>	 <p><b>477F</b> PUMP PLUNGER BOOT</p>	 <p><b>31-209</b> NEEDLE &amp; SEAT ASSEMBLY</p>
--	--	---

**REFERENCE**

**WALKER CARBURETOR  
KIT #15561B**

# HITACHI

**"APPLICATION"**

**SUBARU (4 cyl).....1979-70**



**90-39**  
**CHECK BALL**  
**5/32" NYLON**



**32-10**  
**COTTER PIN**

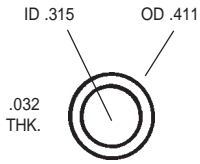

**G59**  
**FUEL INLET**  
**WASHER**

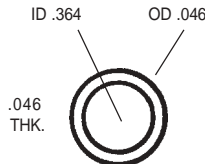

**608F**  
**MAIN JET**  
**WASHER**

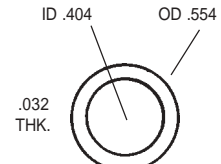

**397F**  
**INLET FITTING**  
**WASHER**

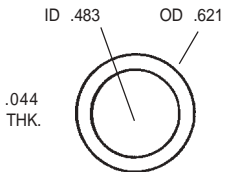

**824F**  
**FUEL VALVE**  
**WASHER**

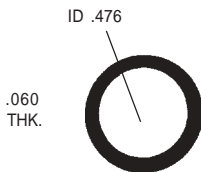

**685F**  
**THROTTLE BYPASS**  
**VALVE O-RING**

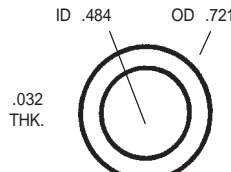

**11F**  
**BANJO UNION**  
**BOLT WASHER**

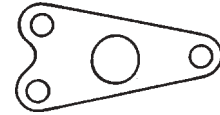

**513F**  
**SOLENOID VALVE**  
**GASKET**

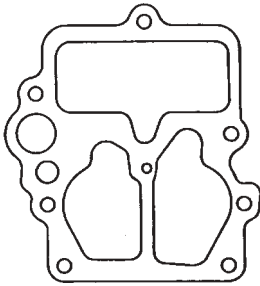

**949F (3/64)**  
**328F (1/32)**  
**BOWL COVER GASKET**

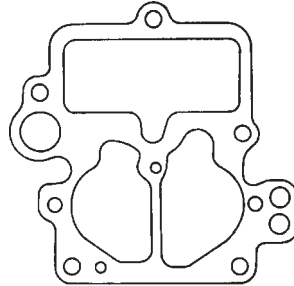

**330F**  
**BOWL COVER**  
**GASKET**

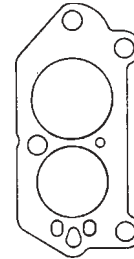

**512F**  
**THROTTLE BODY**  
**GASKET**

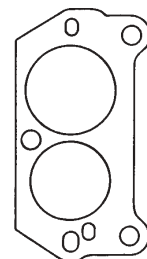

**818F**  
**THROTTLE BODY**  
**GASKET**

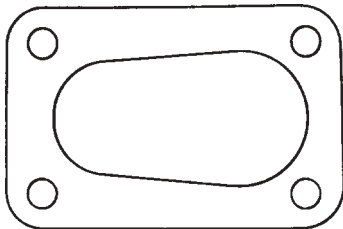

**414F**  
**FLANGE GASKET**

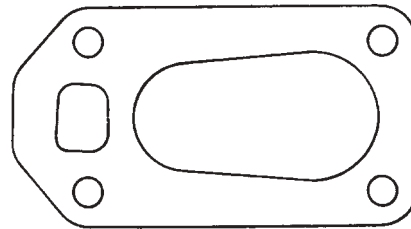

**415F**  
**FLANGE GASKET**

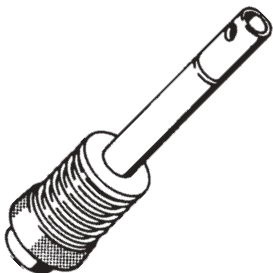

**764F**  
**PUMP PLUNGER**  
**ASSEMBLY**



**547F**  
**PUMP PLUNGER**  
**BOOT**



**31-608**  
**NEEDLE & SEAT**  
**ASSEMBLY**

**REFERENCE**  
**WALKER CARBURETOR KITS**  
**#15566,15567,15568**

# HITACHI

**"APPLICATION"**  
**15566 NISSAN (6 cyl).....1971-67**  
**15567 NISSAN (6 cyl).....1972**  
**15568 NISSAN (6 cyl).....1972**

ID .259    OD .405

.032 THK.

**G37**  
**PUMP DISCHARGE**  
**NOZZLE WASHER**

ID .315    OD .411

.032 THK.

**G59**  
**FUEL INLET**  
**WASHER**

ID .408    OD .565

.032 THK.

**245F**  
**MAIN JET**  
**PLUG WASHER**

ID .484    OD .721

.032 THK.

**11F**  
**BANJO UNION**  
**BOLT WASHER**

ID .505    OD .746

.045 THK.

**792F**  
**PLASTIC PISTON**  
**DAMPER WASHER**

ID .696    OD .885

.047 THK.

**793F**  
**MIXING CHAMBER**  
**TOP WASHER**

**508F**  
**BOWL COVER**  
**GASKET**

**502F**  
**FLANGE GASKET**

**928F**  
**RUBBER NOZZLE TUBE**  
**11/64" I.D. 4" LONG**

**31-604**  
**NEEDLE & SEAT**  
**ASSEMBLY**  
**(Used in kit #15568)**

**31-606**  
**NEEDLE & SEAT**  
**ASSEMBLY**  
**(Used in kit #15566)**

**31-607**  
**NEEDLE & SEAT**  
**ASSEMBLY**  
**(Used in kit #15567)**

**REFERENCE**

**WALKER CARBURETOR  
KIT #15569**

# HITACHI

**"APPLICATION"**

**NISSAN (6 cyl).....1975-73**

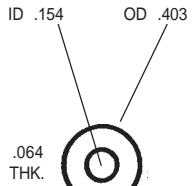

**846F**  
POWER VALVE  
SEAT WASHER

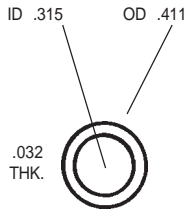

**G59**  
FUEL INLET  
WASHER

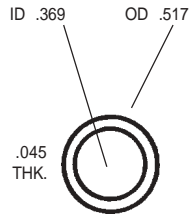

**2F**  
NEEDLE SEAT  
WASHER

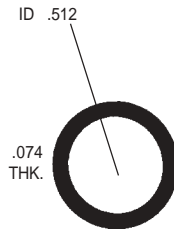

**794F**  
O-RING SEAL

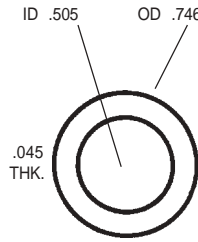

**792F**  
PLASTIC PISTON  
DAMPER WASHER

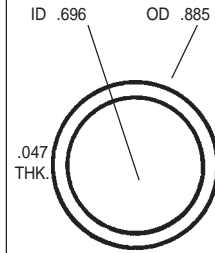

**793F**  
MIXING CHAMBER  
TOP WASHER

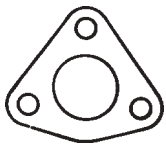

**531F**  
FUEL SIGHT  
WINDOW GASKET

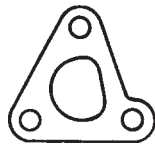

**538F**  
FUEL SIGHT  
WINDOW GASKET

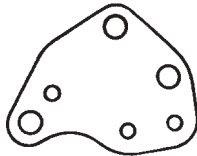

**532F**  
POWER VALVE  
MOUNTING GASKET

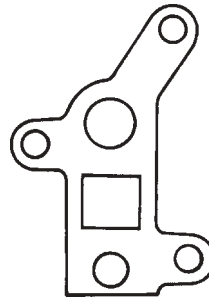

**524F**  
IMS BLOCK  
GASKET

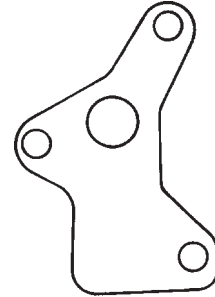

**525F**  
IMS BLOCK  
GASKET

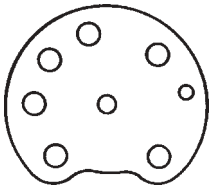

**537F**  
POWER VALVE  
DIAPHRAGM

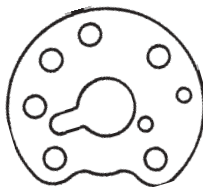

**526F**  
POWER VALVE  
CIRCUIT PLATE GASKET

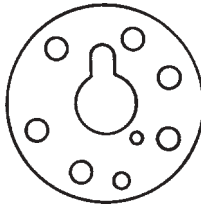

**527F**  
POWER VALVE  
CIRCUIT PLATE GASKET

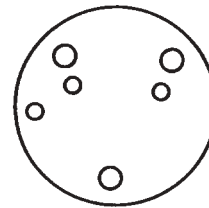

**528F**  
POWER VALVE  
MOUNTING GASKET

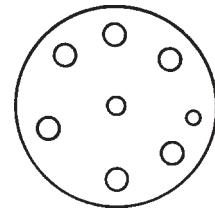

**536F**  
POWER VALVE  
DIAPHRAGM

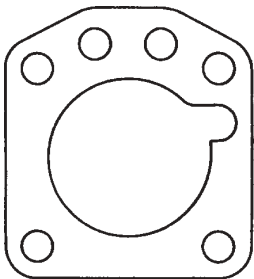

**502F**  
FLANGE GASKET

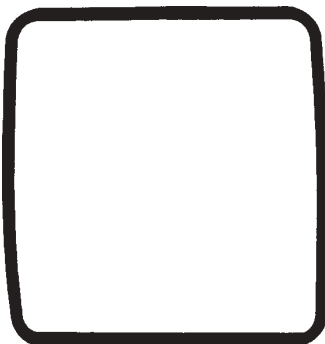

**683F**  
RUBBER FUEL  
BOWL SEAL

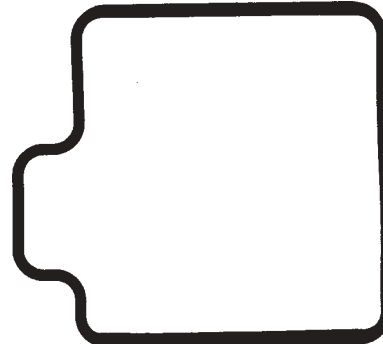

**684F**  
RUBBER FUEL  
BOWL SEAL



**31-608**  
NEEDLE & SEAT  
ASSEMBLY



**REFERENCE**  
**WALKER CARBURETOR**  
**KIT #15612**

# HITACHI

**"APPLICATION"**  
**MAZDA (Rotary).....1976-74**



**90-12**  
**CHECK BALL**  
**5/32" STEEL**



**90-39**  
**CHECK BALL**  
**5/32" NYLON**



**32-55**  
**COTTER PIN**

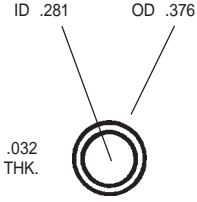

**579F**  
**DISCHARGE JET**  
**WASHER**

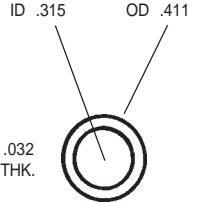

**G59**  
**FUEL INLET**  
**WASHER**

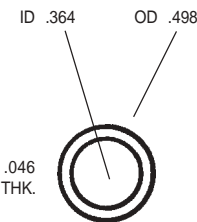

**608F**  
**MAIN JET**  
**WASHER**

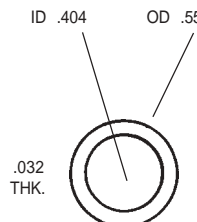

**397F**  
**INLET FITTING**  
**WASHER**

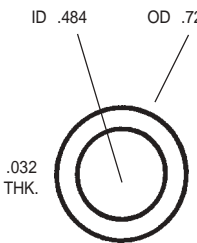

**11F**  
**BANJO UNION**  
**BOLT WASHER**

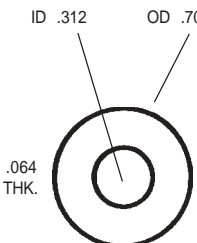

**74F**  
**UPPER INLET**  
**BANJO WASHER**

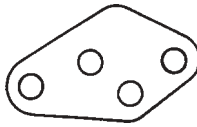

**576F**  
**SEC. DIAPHRAGM**  
**MOUNTING GASKET**

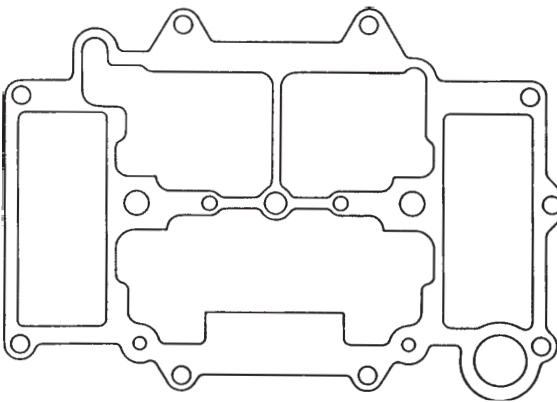

**575F**  
**BOWL COVER GASKET**

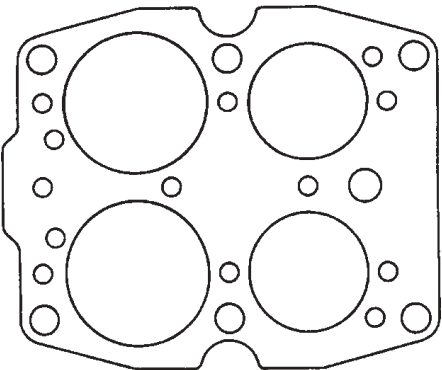

**578F**  
**THROTTLE BODY GASKET**

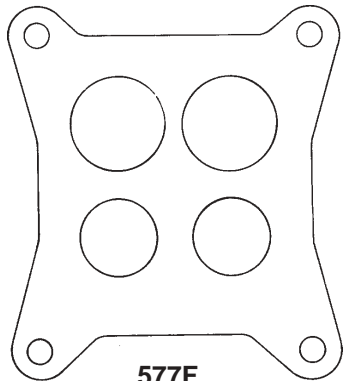

**577F**  
**FLANGE GASKET**

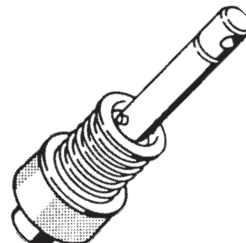

**753F**  
**PUMP PLUNGER**  
**ASSEMBLY**



**31-206**  
**NEEDLE & SEAT**  
**ASSEMBLY**



**REFERENCE**





**WALKER CARBURETOR  
KIT #15614B**

# HITACHI

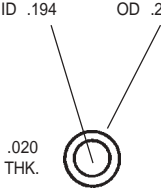
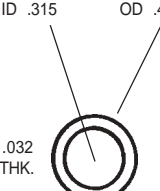
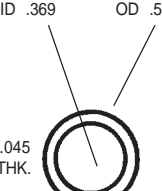

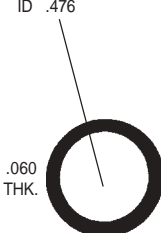
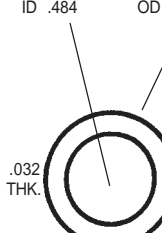

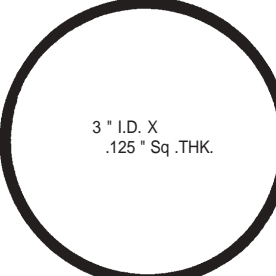
**"APPLICATION"**

**COURIER (4 cyl).....1982-75  
MAZDA (4 cyl).....1980-75**

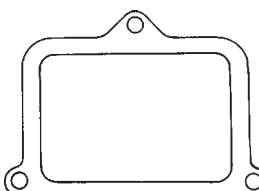
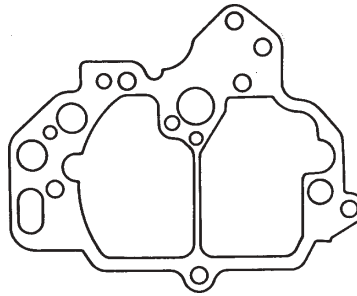
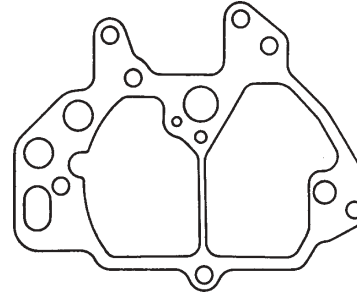
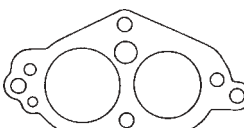
 <p><b>90-39</b> CHECK BALL 5/32" NYLON</p>	 <p><b>90-12</b> CHECK BALL 5/32" STEEL</p>	 <p><b>32-10</b> COTTER PIN</p>	 <p><b>610F</b> ALUM. MAIN JET WASHER</p>	 <p><b>G59</b> FUEL INLET WASHER</p>	 <p><b>2F</b> NEEDLE SEAT WASHER</p>
--	--	--	--	--	---

 <p><b>685F</b> THROTTLE BYPASS VALVE O-RING</p>	 <p><b>11F</b> BANJO UNION BOLT WASHER</p>	 <p><b>74F</b> UPPER INLET BANJO WASHER</p>	 <p><b>333F</b> RUBBER FUEL WINDOW SEAL</p>	 <p><b>349F</b> PUMP RETAINER GASKET</p>	 <p><b>357F</b> SEC. DIAPHRAGM GASKET</p>
--	---	--	---	---	--

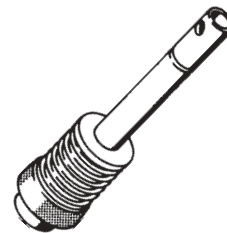
 <p><b>332F</b> FUEL BOWL WINDOW GASKET</p>	 <p><b>493F</b> BOWL COVER GASKET</p>	 <p><b>523F</b> BOWL COVER GASKET</p>	 <p><b>778F</b> THROTTLE BODY GASKET</p>
---	--	---	---

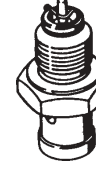

 <p><b>519F</b> FLANGE GASKET</p>	 <p><b>905F</b> CHOKE COVER POP RIVET</p>	 <p><b>757F</b> PUMP PLUNGER ASSEMBLY</p>	 <p><b>477F</b> PUMP PLUNGER BOOT</p>	 <p><b>31-209</b> NEEDLE &amp; SEAT ASSEMBLY</p>
--	--	--	---	---





**REFERENCE**  
**WALKER CARBURETOR**  
**KIT #15616A**

# HITACHI

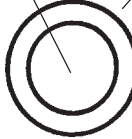
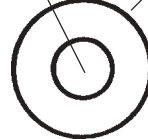

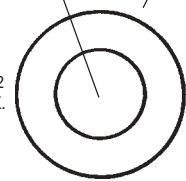
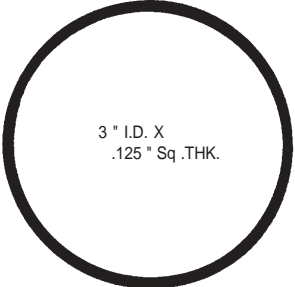
**"APPLICATION"**  
**NISSAN (4 cyl).....1980-75**

 <b>90-12</b> <b>CHECK BALL</b> <b>5/32" STEEL</b>	 <b>62-57</b> <b>"E" CLIP</b> <b>RETAINER</b>	 <b>62-64</b> <b>PUMP RETAINER</b>	 <b>32-10</b> <b>COTTER PIN</b>	 <b>32-20</b> <b>COTTER PIN</b>
--	---	---	--	--

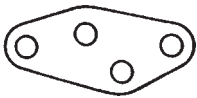
 ID .238 .048 THK. <b>G929</b> <b>VACUUM PISTON</b> <b>SEAL O-RING</b>	 ID .315    OD .411 .032 THK. <b>G59</b> <b>FUEL INLET</b> <b>WASHER</b>	 ID .369    OD .517 .045 THK. <b>2F</b> <b>NEEDLE SEAT</b> <b>WASHER</b>	 ID .484    OD .721 .032 THK. <b>11F</b> <b>BANJO UNION</b> <b>BOLT WASHER</b>	 ID .312    OD .702 .064 THK. <b>74F</b> <b>UPPER INLET</b> <b>BANJO WASHER</b>
--	--	--	--	---

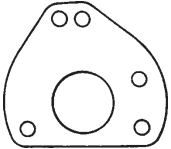
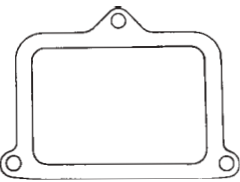
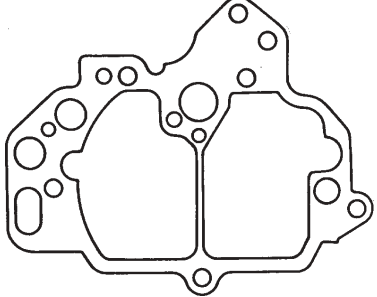
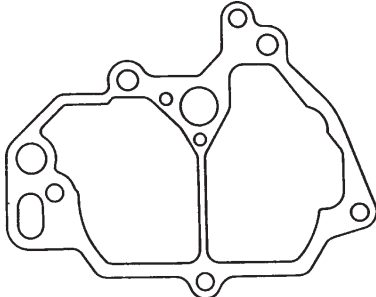
 ID .469    OD .874 .032 THK. <b>26F</b> <b>LOWER BANJO</b> <b>FITTING WASHER</b>	 3" I.D. X .125" Sq. THK. <b>333F</b> <b>RUBBER FUEL</b> <b>WINDOW SEAL</b>	 <b>380F</b> <b>PRI. VENTURI</b> <b>GASKET</b>	 <b>347F</b> <b>SEC. VENTURI</b> <b>GASKET</b>	 <b>349F</b> <b>PUMP RETAINER</b> <b>GASKET</b>	 <b>357F</b> <b>SEC. DIAPHRAGM</b> <b>GASKET</b>
---	---	--	--	---	--

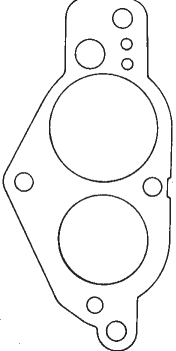
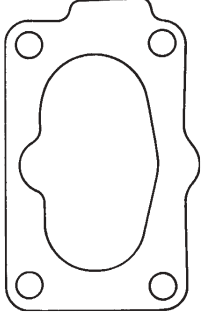
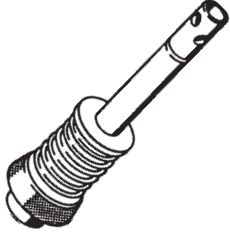
 <b>362F</b> <b>CONTROL UNIT</b> <b>GASKET</b>	 <b>332F</b> <b>FUEL BOWL</b> <b>WINDOW GASKET</b>	 <b>493F</b> <b>BOWL COVER</b> <b>GASKET</b>	 <b>507F</b> <b>BOWL COVER</b> <b>GASKET</b>
--	--	---	--

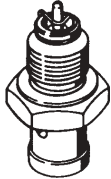
 <b>607F</b> <b>THROTTLE BODY</b> <b>GASKET</b>	 <b>519F</b> <b>FLANGE GASKET</b>	 <b>832F</b> <b>PUMP PLUNGER</b> <b>ASSEMBLY</b>	 <b>477F</b> <b>PUMP PLUNGER</b> <b>BOOT</b>	 <b>31-208</b> <b>NEEDLE &amp; SEAT</b> <b>ASSEMBLY</b>
---	--	--	--	---



**REFERENCE**

WALKER CARBURETOR  
KIT #15712



# HITACHI

**"APPLICATION"**

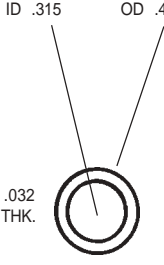
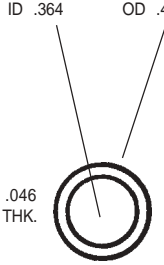
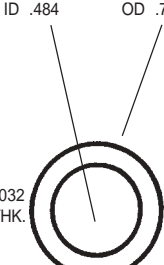
MAZDA (4 cyl).....1980  
NISSAN (4 cyl).....1980-78

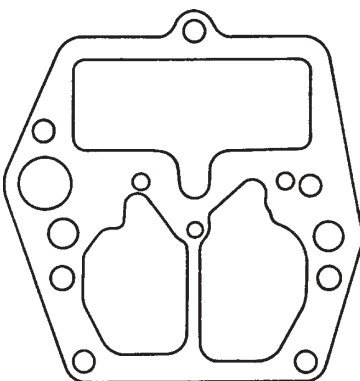
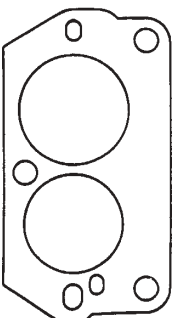
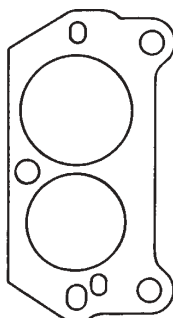
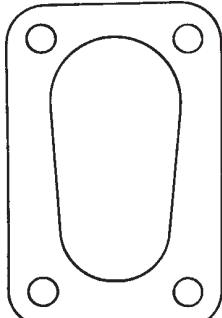
 <p><b>90-12</b> CHECK BALL 5/32" STEEL</p>	 <p><b>62-57</b> "E" CLIP RETAINER</p>	 <p><b>32-11</b> COTTER PIN</p>	<p>ID .315    OD .411</p>  <p>.032 THK.</p> <p><b>G59</b> FUEL INLET WASHER</p>	<p>ID .364    OD .498</p>  <p>.046 THK.</p> <p><b>608F</b> MAIN JET WASHER</p>	<p>ID .484    OD .721</p>  <p>.032 THK.</p> <p><b>11F</b> BANJO UNION BOLT WASHER</p>
--	---	--	--	--	--

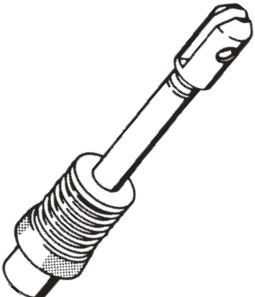
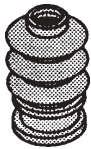
 <p><b>452F</b> BOWL COVER GASKET</p>	 <p><b>514F</b> THROTTLE BODY GASKET</p>	 <p><b>818F</b> THROTTLE BODY GASKET</p>	 <p><b>414F</b> FLANGE GASKET</p>
--	--	---	---

 <p><b>756F</b> PUMP PLUNGER ASSEMBLY</p>	 <p><b>547F</b> PUMP PLUNGER BOOT</p>	 <p><b>31-206</b> NEEDLE &amp; SEAT ASSEMBLY</p>
--	--	---

**REFERENCE**  
**WALKER CARBURETOR**  
**KIT #15780A**

# HITACHI

**"APPLICATION"**  
**SUBARU (4 cyl).....1980**



**90-39**  
**CHECK BALL**  
**5/32" NYLON**



**62-90**  
**"E" CLIP**  
**RETAINER**



**32-10**  
**COTTER PIN**

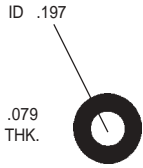

ID .197  
 .079 THK.

**1041F**  
**IDLE NEEDLE**  
**SCREW O-RING**

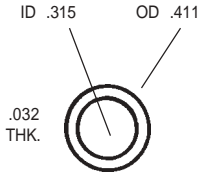

ID .315 OD .411  
 .032 THK.

**G59**  
**FUEL INLET**  
**WASHER**

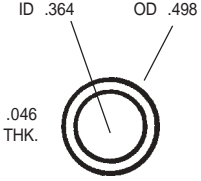

ID .364 OD .498  
 .046 THK.

**608F**  
**MAIN JET**  
**WASHER**



ID .476  
 .060 THK.

**685F**  
**THROTTLE BYPASS**  
**VALVE O-RING**



ID .470 OD .626  
 .023 THK.

**912F**  
**COPPER NEEDLE**  
**SEAT GASKET**



ID .541  
 .052 THK.

**733F**  
**BOWL VENT**  
**SOLENOID O-RING**

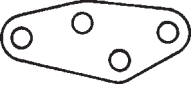

**732F**  
**SEC. DIAPHRAGM**  
**GASKET**

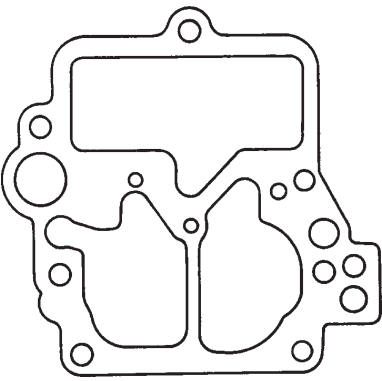

**734F**  
**BOWL COVER**  
**GASKET**

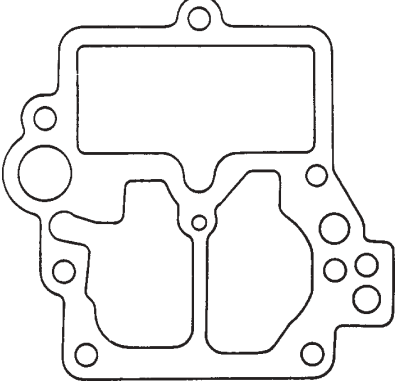

**910F**  
**BOWL COVER**  
**GASKET**

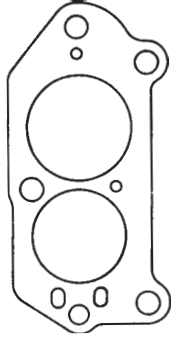

**735F**  
**THROTTLE BODY**  
**INSULATOR GASKET**

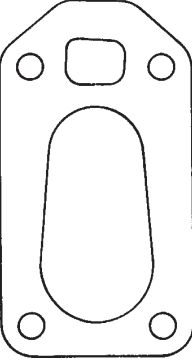

**415F**  
**FLANGE GASKET**

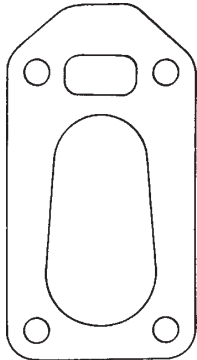

**909F**  
**FLANGE GASKET**

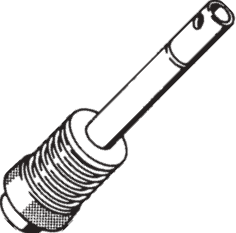

**764F**  
**PUMP PLUNGER**  
**ASSEMBLY**



**547F**  
**PUMP PLUNGER**  
**BOOT**



**31-621**  
**NEEDLE & SEAT**  
**ASSEMBLY**













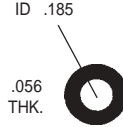
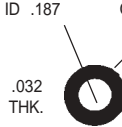

**REFERENCE**

**WALKER CARBURETOR  
KIT #15792B**

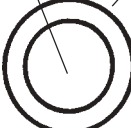
# HITACHI

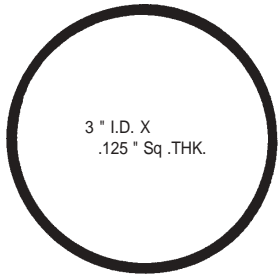
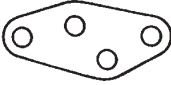
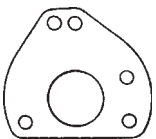
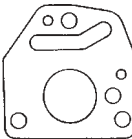
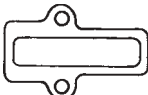
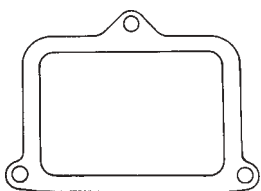
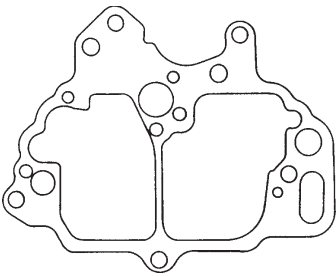
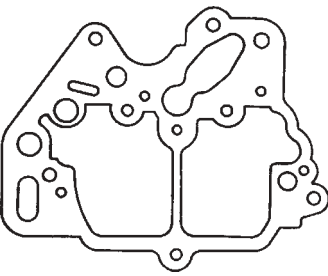
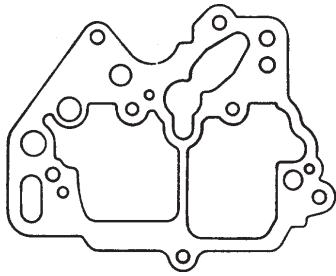
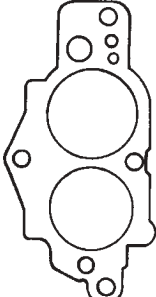
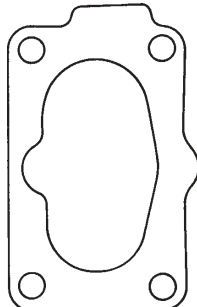
**"APPLICATION"**

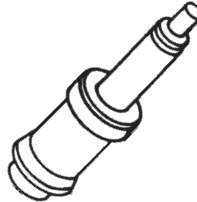
**NISSAN (4 cyl).....1986-80**

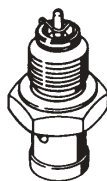
 <p><b>90-12</b> CHECK BALL 5/32" STEEL</p>	 <p><b>62-57</b> "E" CLIP RETAINER</p>	 <p><b>62-63</b> "E" CLIP RETAINER</p>	 <p><b>32-11</b> COTTER PIN</p>	 <p>ID .185 .056 THK.</p> <p><b>795F</b> PUMP DISCHARGE NOZZLE O-RING</p>	 <p>ID .187 OD .312 .032 THK.</p> <p><b>G495</b> RUBBER CHOKE HOUSING WASHER</p>
 <p>ID .238 .048 THK.</p> <p><b>G929</b> VACUUM PISTON SEAL O-RING</p>	 <p>ID .315 OD .411 .032 THK.</p> <p><b>G59</b> FUEL INLET WASHER</p>	 <p>ID .369 OD .517 .045 THK.</p> <p><b>2F</b> NEEDLE SEAT WASHER</p>	 <p>ID .484 OD .721 .032 THK.</p> <p><b>11F</b> BANJO UNION BOLT WASHER</p>	 <p>ID .312 OD .702 .064 THK.</p> <p><b>74F</b> UPPER INLET BANJO WASHER</p>	
 <p>3" I.D. X .125" Sq. THK.</p> <p><b>333F</b> RUBBER FUEL WINDOW SEAL</p>	 <p><b>357F</b> SEC. DIAPHRAGM GASKET</p>	 <p><b>362F</b> CONTROL UNIT GASKET</p>	 <p><b>791F</b> BYPASS AIR CONTROL GASKET</p>	 <p><b>906F</b> IDLE COMPENSATOR GASKET</p>	
 <p><b>332F</b> FUEL BOWL WINDOW GASKET</p>	 <p><b>950F</b> BOWL COVER GASKET</p>	 <p><b>1080F</b> BOWL COVER GASKET</p>	 <p><b>1168F</b> BOWL COVER GASKET</p>		
 <p><b>985F</b> THROTTLE BODY GASKET</p>	 <p><b>519F</b> FLANGE GASKET</p>	 <p><b>907F</b> CHOKE COVER POP RIVET</p>	 <p><b>866F</b> PUMP PLUNGER ASSEMBLY</p>	 <p><b>862F</b> PUMP PLUNGER BOOT</p>	 <p><b>31-208</b> NEEDLE &amp; SEAT ASSEMBLY</p>







**REFERENCE**







**WALKER CARBURETOR  
KIT #15831**



# HITACHI

**"APPLICATION"**

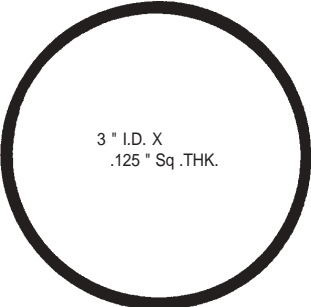

CHEV./GMC TRUCK (4 cyl).....1985-82  
ISUZU (4 cyl).....1987-81  
LUV TRUCK (4 cyl).....1982-81

				 ID .176 .070 THK.	 ID .187 OD .312 .032 THK.	 ID .238 .048 THK.
<b>90-12</b> CHECK BALL 5/32" STEEL	<b>90-39</b> CHECK BALL 5/32" NYLON	<b>62-64</b> PUMP RETAINER	<b>32-10</b> COTTER PIN	<b>G273</b> SEC. CONNECTING TUBE O-RING	<b>G495</b> RUBBER CHOKE HOUSING WASHER	<b>G929</b> VACUUM PISTON SEAL O-RING

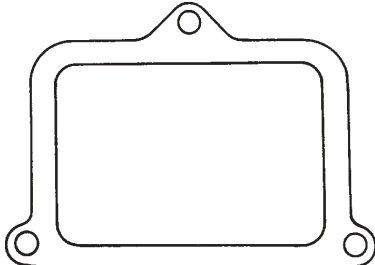
 ID .315 OD .411 .032 THK.	 ID 369 OD .517 .045 THK.	 ID .476 .060 THK.	 ID .484 .032 THK.	 ID .484 OD .721 .032 THK.	 ID .312 OD .702 .064 THK.
<b>G59</b> FUEL INLET WASHER	<b>2F</b> NEEDLE SEAT WASHER	<b>685F</b> THROTTLE BYPASS VALVE O-RING	<b>733F</b> BOWL VENT SOLENOID O-RING	<b>11F</b> BANJO UNION BOLT WASHER	<b>74F</b> UPPER INLET BANJO WASHER

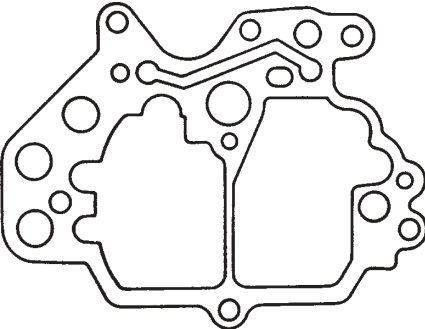
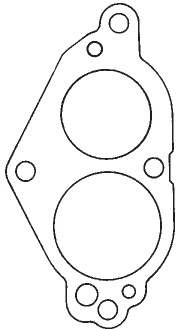
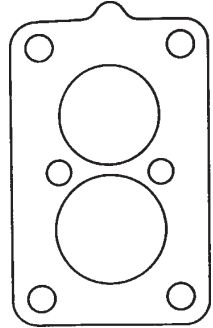
 3" I.D. X .125" Sq .THK.			
<b>333F</b> RUBBER FUEL WINDOW SEAL	<b>349F</b> PUMP RETAINER GASKET	<b>357F</b> SEC. DIAPHRAGM GASKET	<b>332F</b> FUEL BOWL WINDOW GASKET

		
<b>662F</b> BOWL COVER GASKET	<b>777F</b> THROTTLE BODY GASKET	<b>311F</b> FLANGE GASKET

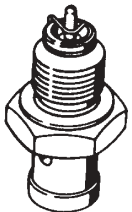
		
<b>916F</b> CHOKE COVER POP RIVET	<b>477F</b> PUMP PLUNGER BOOT	<b>31-213</b> NEEDLE & SEAT ASSEMBLY















**REFERENCE**

**WALKER CARBURETOR  
KIT #15843**

# HITACHI

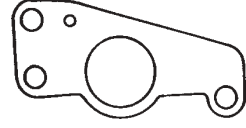
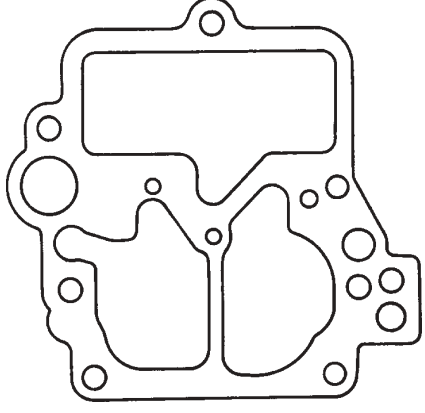
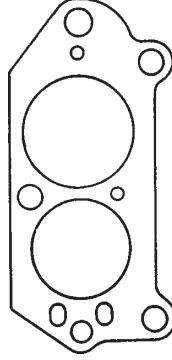
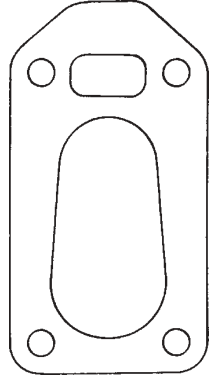
**"APPLICATION"**

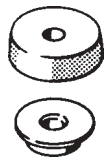
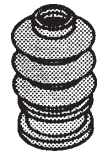
**SUBARU (4 cyl).....1981**

 <p><b>90-39</b> CHECK BALL 5/32" NYLON</p>	 <p><b>62-57</b> "E" CLIP RETAINER</p>	 <p><b>62-90</b> "E" CLIP RETAINER</p>	 <p><b>32-10</b> COTTER PIN</p>	 <p>ID .335 .059 THK.</p> <p><b>1041F</b> IDLE MIXTURE SCREW O-RING</p>	 <p>ID .315 OD .411 .032 THK.</p> <p><b>G59</b> FUEL INLET WASHER</p>
 <p>ID .364 OD .498 .046 THK.</p> <p><b>608F</b> MAIN JET WASHER</p>	 <p>ID .476 .060 THK.</p> <p><b>685F</b> THROTTLE BYPASS VALVE O-RING</p>	 <p>ID .470 OD .626 .023 THK.</p> <p><b>912F</b> COPPER NEEDLE SEAT WASHER</p>	 <p><b>732F</b> SEC. DIAPHRAGM GASKET</p>	 <p><b>914F</b> BOWL VENT SWITCH GASKET</p>	
 <p><b>734F</b> BOWL COVER GASKET</p>		 <p><b>982F</b> THROTTLE BODY INSULATOR GASKET</p>	 <p><b>909F</b> FLANGE GASKET</p>		
 <p><b>916F</b> CHOKE COVER POP RIVET</p>	 <p><b>983F</b> PUMP PLUNGER ASSEMBLY</p>	 <p><b>547F</b> PUMP PLUNGER BOOT</p>	 <p><b>31-223</b> NEEDLE &amp; SEAT ASSEMBLY</p>		

















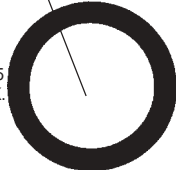

**REFERENCE**

**WALKER CARBURETOR  
KIT #15844**

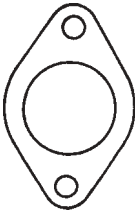
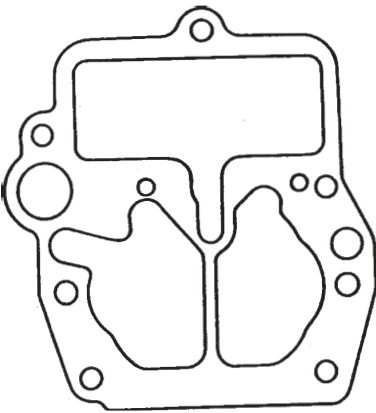
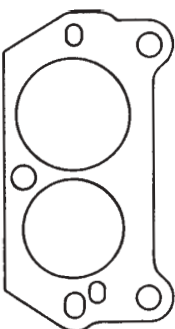
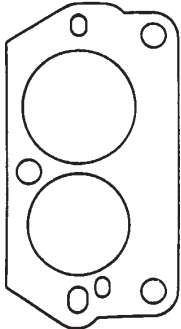
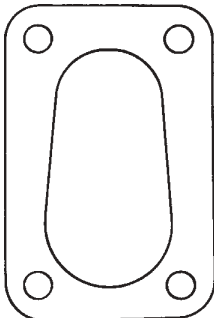
# HITACHI

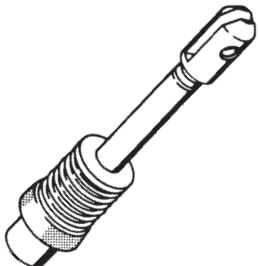
**"APPLICATION"**

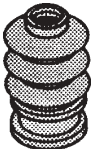
**NISSAN (4 cyl).....1983-81**

 <p><b>90-12</b> CHECK BALL 5/32" STEEL</p>	 <p><b>62-90</b> "E" CLIP RETAINER</p>	 <p><b>32-11</b> COTTER PIN</p>	 <p><b>32-10</b> COTTER PIN</p>	 <p>ID .185 .056 THK.</p> <p><b>795F</b> PUMP DISCHARGE NOZZLE O-RING</p>	 <p>ID .238 .048 THK.</p> <p><b>G929</b> VACUUM PISTON SEAL O-RING</p>
 <p>ID .315 OD .411 .032 THK.</p> <p><b>G59</b> FUEL INLET WASHER</p>	 <p>ID .364 OD .498 .046 THK.</p> <p><b>608F</b> MAIN JET WASHER</p>	 <p>ID .484 OD .721 .032 THK.</p> <p><b>11F</b> BANJO UNION BOLT WASHER</p>	 <p>ID .720 .095 THK.</p> <p><b>932F</b> O-RING SEAL</p>	 <p><b>790F</b> SEC. DIAPHRAGM MOUNTING GASKET</p>	 <p><b>908F</b> FLOAT BOWL WINDOW GASKET</p>
 <p><b>789F</b> BOWL COVER GASKET</p>		 <p><b>818F</b> THROTTLE BODY GASKET</p>	 <p><b>514F</b> THROTTLE BODY GASKET</p>	 <p><b>414F</b> FLANGE GASKET</p>	
 <p><b>905F</b> CHOKE COVER POP RIVET</p>	 <p><b>756F</b> PUMP PLUNGER ASSEMBLY</p>	 <p><b>1029F</b> PUMP CUP</p>	 <p><b>547F</b> PUMP PLUNGER BOOT</p>	 <p><b>31-223</b> NEEDLE &amp; SEAT ASSEMBLY</p>	





















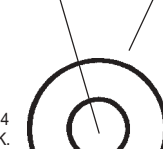
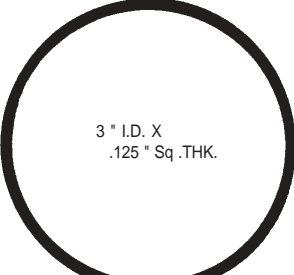

**REFERENCE**

**WALKER CARBURETOR  
KIT #15849A**

# HITACHI

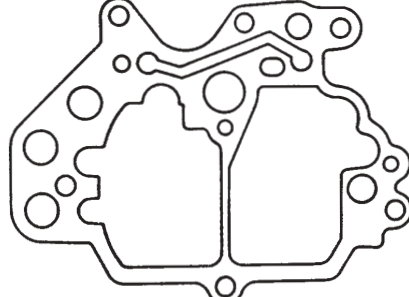
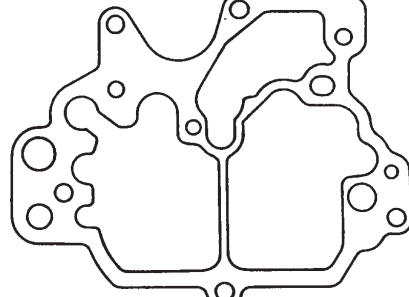
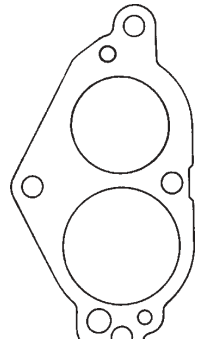
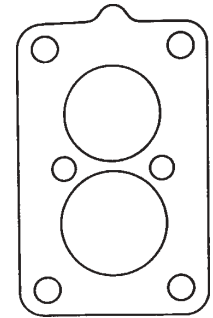
**"APPLICATION"**

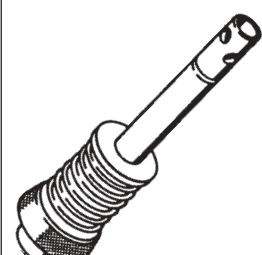

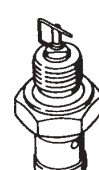

CHEV./GMC TRUCK (CA.) (4 cyl).....1984-82  
ISUZU (4 cyl).....1985-82  
LUV TRUCK (CA.) (4 cyl).....1982



 <p><b>90-12</b> CHECK BALL 5/32" STEEL</p>	 <p><b>62-57</b> "E" CLIP RETAINER</p>	 <p><b>32-10</b> COTTER PIN</p>	 <p>ID .176 .070 THK.</p> <p><b>G273</b> SEC. CONNECTING TUBE O-RING</p>	 <p>ID .187 OD .312 .032 THK.</p> <p><b>G495</b> RUBBER CHOKE HOUSING WASHER</p>	 <p>ID .238 .048 THK.</p> <p><b>G929</b> VACUUM PISTON SEAL O-RING</p>	 <p>ID .276 .059 THK.</p> <p><b>1007F</b> LOWER FEEDBACK O-RING</p>
 <p>ID .270 .053 THK.</p> <p><b>775F</b> O-RING</p>	 <p>ID .315 OD .411 .032 THK.</p> <p><b>G59</b> FUEL INLET WASHER</p>	 <p>ID .354 .059 THK.</p> <p><b>1006F</b> UPPER FEEDBACK O-RING</p>	 <p>ID .369 OD .517 .045 THK.</p> <p><b>2F</b> NEEDLE SEAT WASHER</p>	 <p>ID .426 .065 THK.</p> <p><b>847F</b> FLOAT CHAMBER PLUG O-RING</p>	 <p>ID .476 .060 THK.</p> <p><b>685F</b> THROTTLE BYPASS VALVE O-RING</p>	
 <p>ID .541 .052 THK.</p> <p><b>733F</b> BOWL VENT SOLENOID O-RING</p>	 <p>ID .484 OD .721 .032 THK.</p> <p><b>11F</b> BANJO UNION BOLT WASHER</p>	 <p>ID .312 OD .702 .064 THK.</p> <p><b>74F</b> UPPER INLET BANJO WASHER</p>	 <p>3" I.D. X .125" Sq. THK.</p> <p><b>333F</b> RUBBER FUEL WINDOW SEAL</p>	 <p><b>349F</b> PUMP RETAINER GASKET</p>		
 <p><b>770F</b> BOWL WINDOW GASKET</p>	 <p><b>357F</b> SEC. DIAPHRAGM GASKET</p>	 <p><b>662F</b> BOWL COVER GASKET</p>	 <p><b>1102F</b> BOWL COVER GASKET</p>			
 <p><b>777F</b> THROTTLE BODY GASKET</p>	 <p><b>311F</b> FLANGE GASKET</p>	 <p><b>916F</b> CHOKE COVER POP RIVET</p>	 <p><b>832F</b> PUMP PLUNGER ASSEMBLY</p>	 <p><b>477F</b> PUMP PLUNGER BOOT</p>	 <p><b>31-670</b> NEEDLE &amp; SEAT ASSEMBLY</p>	

**REFERENCE**  
**WALKER CARBURETOR**  
**KIT #15853A**



# HITACHI

**"APPLICATION"**  
**SUBARU (4 cyl).....1989-82**

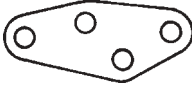
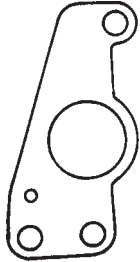
 <p><b>90-39</b>  <b>CHECK BALL</b>  <b>5/32" NYLON</b></p>	 <p><b>62-90</b>  <b>"E" CLIP</b>  <b>RETAINER</b></p>	 <p><b>32-10</b>  <b>COTTER PIN</b></p>	 <p>ID .238          .048 THK.</p> <p><b>G929</b>  <b>VACUUM PISTON</b>  <b>SEAL O-RING</b></p>	 <p>ID .197          .079 THK.</p> <p><b>1041F</b>  <b>IDLE MIXTURE</b>  <b>SCREW O-RING</b></p>
--	---	--	--	---

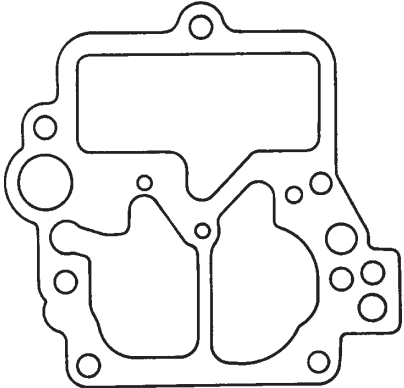
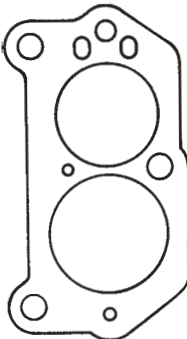
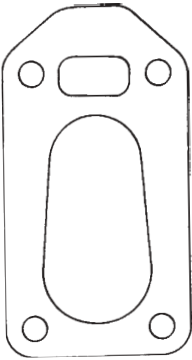
 <p>ID .315 OD .411          .032 THK.</p> <p><b>G59</b>  <b>FUEL INLET</b>  <b>WASHER</b></p>	 <p>ID .364 OD .498          .046 THK.</p> <p><b>608F</b>  <b>MAIN JET</b>  <b>WASHER</b></p>	 <p>ID .470 OD .626          .023 THK.</p> <p><b>912F</b>  <b>COPPER NEEDLE</b>  <b>SEAT GASKET</b></p>	 <p><b>732F</b>  <b>SECONDARY DIAPHRAGM</b>  <b>GASKET</b></p>	 <p><b>914F</b>  <b>BOWL VENT</b>  <b>SWITCH GASKET</b></p>
---	--	--	---	--

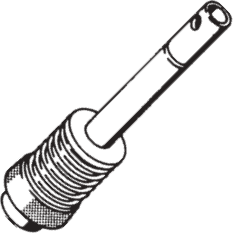
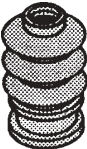
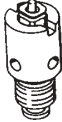
 <p><b>734F</b>  <b>BOWL COVER</b>  <b>GASKET</b></p>	 <p><b>915F</b>  <b>THROTTLE BODY</b>  <b>GASKET</b></p>	 <p><b>909F</b>  <b>FLANGE GASKET</b></p>
--	--	--

 <p><b>916F</b>  <b>CHOKE COVER</b>  <b>POP RIVET</b></p>	 <p><b>764F</b>  <b>PUMP PLUNGER</b>  <b>ASSEMBLY</b></p>	 <p><b>547F</b>  <b>PUMP PLUNGER</b>  <b>BOOT</b></p>	 <p><b>31-657</b>  <b>NEEDLE &amp; SEAT</b>  <b>ASSEMBLY</b></p>	 <p><b>31-651</b>  <b>NEEDLE &amp; SEAT</b>  <b>ASSEMBLY</b></p>
--	--	--	---	---







**REFERENCE**



**WALKER CARBURETOR  
KIT #15870**

# HITACHI



**"APPLICATION"**

**NISSAN (4 cyl).....1984-83**

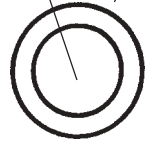
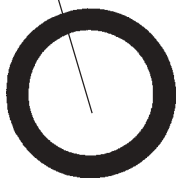
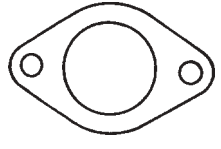
 <p><b>90-12</b> CHECK BALL 5/32" STEEL</p>	 <p><b>32-11</b> COTTER PIN</p>	 <p><b>32-10</b> COTTER PIN</p>	 <p><b>62-90</b> "E" CLIP RETAINER</p>	 <p>ID .185 .056 THK.</p> <p><b>795F</b> PUMP DISCHARGE NOZZLE O-RING</p>	 <p>ID .238 .048 THK.</p> <p><b>G929</b> VACUUM PISTON SEAL O-RING</p>	 <p>ID .276 .059 THK.</p> <p><b>1007F</b> LOWER FEEDBACK O-RING</p>
--	--	--	---	--	---	--

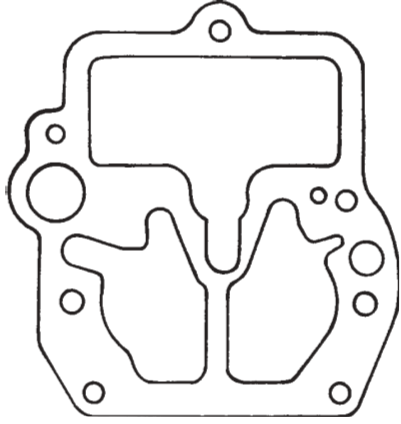
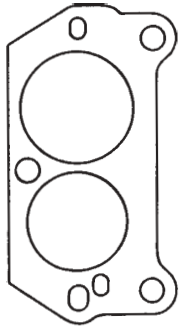
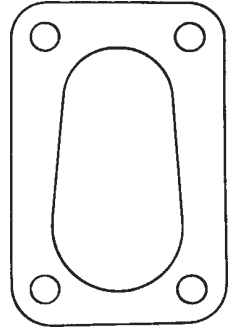
 <p>ID .354 .059 THK.</p> <p><b>1006F</b> UPPER FEEDBACK O-RING</p>	 <p>ID .364 OD .498 .046 THK.</p> <p><b>608F</b> MAIN JET WASHER</p>	 <p>ID .484 OD .721 .032 THK.</p> <p><b>11F</b> BANJO UNION BOLT WASHER</p>	 <p>ID .720 .095 THK.</p> <p><b>932F</b> O-RING SEAL</p>	 <p><b>908F</b> FLOAT BOWL WINDOW GASKET</p>
--	---	--	--	---

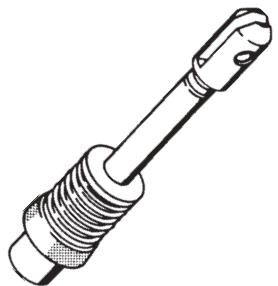
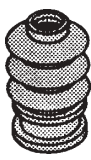















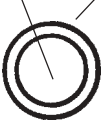

 <p><b>790F</b> SEC. DIAPHRAGM MOUNTING GASKET</p>	 <p><b>1069F</b> BOWL COVER GASKET</p>	 <p><b>818F</b> THROTTLE BODY GASKET</p>	 <p><b>414F</b> FLANGE GASKET</p>
---	---	--	--

 <p><b>916F</b> CHOKE COVER POP RIVET</p>	 <p><b>756F</b> PUMP PLUNGER ASSEMBLY</p>	 <p><b>547F</b> PUMP PLUNGER BOOT</p>	 <p><b>31-654</b> NEEDLE &amp; SEAT ASSEMBLY</p>
--	--	--	---

**REFERENCE**  
**WALKER CARBURETOR**  
**KIT #15871**

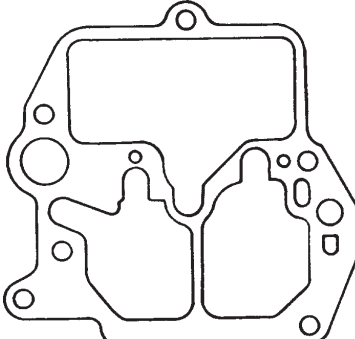
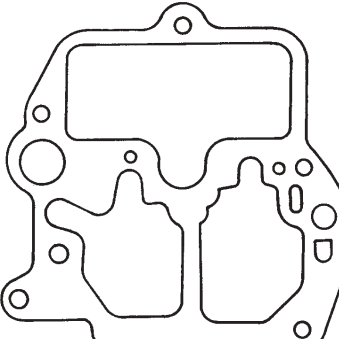
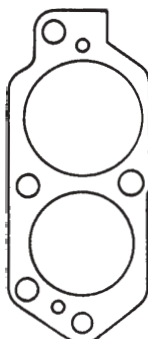
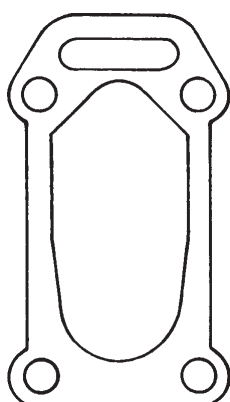
# HITACHI

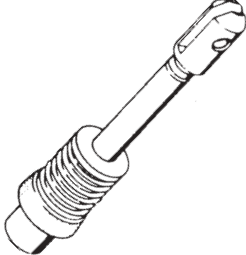
**"APPLICATION"**  
**NISSAN (4 cyl).....1986-83**

 <p><b>62-90</b>  <b>"E" CLIP</b>  <b>RETAINER</b></p>	 <p><b>90-12</b>  <b>CHECK BALL</b>  <b>5/32" STEEL</b></p>	 <p><b>32-46</b>  <b>COTTER PIN</b></p>	 <p><b>32-11</b>  <b>COTTER PIN</b></p>	 <p><b>32-10</b>  <b>COTTER PIN</b></p>
 <p>ID .185          .056 THK.</p> <p><b>795F</b>  <b>PUMP DISCHARGE</b>  <b>NOZZLE O-RING</b></p>	 <p>ID .238          .048 THK.</p> <p><b>G929</b>  <b>VACUUM PISTON</b>  <b>SEAL O-RING</b></p>	 <p>ID .276          .059 THK.</p> <p><b>1007F</b>  <b>LOWER FEEDBACK</b>  <b>O-RING</b></p>	 <p>ID .315 OD .411          .032 THK.</p> <p><b>G59</b>  <b>FUEL INLET</b>  <b>WASHER</b></p>	 <p>ID .354          .059 THK.</p> <p><b>1006F</b>  <b>UPPER FEEDBACK</b>  <b>O-RING</b></p>
 <p>ID .364 OD .498          .046 THK.</p> <p><b>608F</b>  <b>MAIN JET</b>  <b>WASHER</b></p>	 <p>ID .468          .078 THK.</p> <p><b>700F</b>  <b>AIR VALVE</b>  <b>O-RING</b></p>	 <p>ID .484 OD .721          .032 THK.</p> <p><b>11F</b>  <b>BANJO UNION</b>  <b>BOLT WASHER</b></p>	 <p>ID .454 OD .750          .020 THK.</p> <p><b>1052F</b>  <b>BOWL WINDOW</b>  <b>GASKET</b></p>	
 <p><b>987F</b>  <b>BOWL COVER</b>  <b>GASKET</b></p>	 <p><b>990F</b>  <b>BOWL COVER</b>  <b>GASKET</b></p>	 <p><b>1005F</b>  <b>THROTTLE BODY</b>  <b>GASKET</b></p>	 <p><b>1148F</b>  <b>FLANGE GASKET</b>  <b>SKIN</b></p>	
 <p><b>916F</b>  <b>CHOKE COVER</b>  <b>POP RIVET</b></p>	 <p><b>1017F</b>  <b>PUMP PLUNGER</b>  <b>ASSEMBLY</b></p>	 <p><b>547F</b>  <b>PUMP PLUNGER</b>  <b>BOOT</b></p>	 <p><b>31-654</b>  <b>NEEDLE &amp; SEAT</b>  <b>ASSEMBLY</b></p>	







**REFERENCE**





**WALKER CARBURETOR  
KIT #151000B**



# HITACHI

**"APPLICATION"**

**ISUZU (4 cyl).....1991-86  
NISSAN (4 cyl).....1985-83**

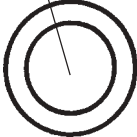
 <p><b>90-12</b> CHECK BALL 5/32" STEEL</p>	 <p><b>32-46</b> COTTER PIN</p>	 <p><b>62-57</b> "E" CLIP RETAINER</p>	 <p><b>62-63</b> "E" CLIP RETAINER</p>	 <p><b>795F</b> PUMP DISCHARGE NOZZLE O-RING</p>	 <p><b>G495</b> RUBBER CHOKE HOUSING WASHER</p>
--	--	---	---	---	--

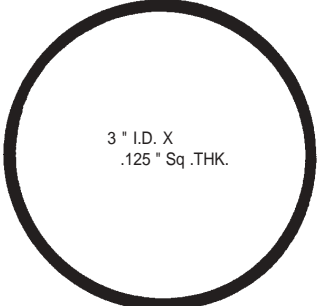
 <p>ID .238 .048 THK.</p> <p><b>G929</b> VACUUM PISTON SEAL O-RING</p>	 <p>ID .276 .059 THK.</p> <p><b>1007F</b> LOWER FEEDBACK O-RING</p>	 <p>ID .315 OD .411 .032 THK.</p> <p><b>G59</b> FUEL INLET WASHER</p>	 <p>ID .354 .059 THK.</p> <p><b>1006F</b> UPPER FEEDBACK O-RING</p>	 <p>ID .484 OD .721 .032 THK.</p> <p><b>11F</b> BANJO UNION BOLT WASHER</p>
---	--	--	---	--

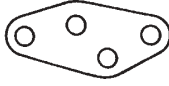
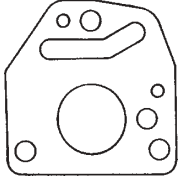
 <p>ID .312 OD .702 .064 THK.</p> <p><b>74F</b> UPPER INLET BANJO WASHER</p>	 <p>3" I.D. X .125" Sq. THK.</p> <p><b>333F</b> RUBBER FUEL WINDOW SEAL</p>	 <p><b>349F</b> PUMP RETAINER GASKET</p>	 <p><b>357F</b> SEC. DIAPHRAGM GASKET</p>	 <p><b>791F</b> BYPASS AIR CONTROL GASKET</p>
---	--	---	---	--

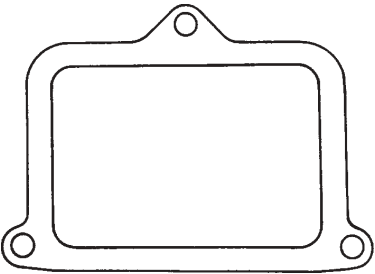
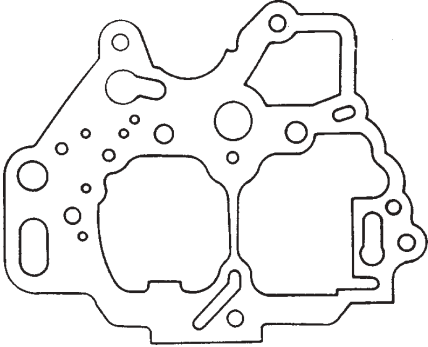
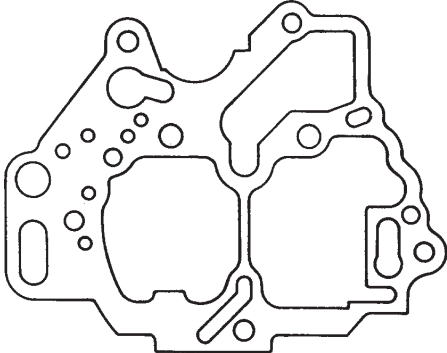
 <p><b>332F</b> FUEL BOWL WINDOW GASKET</p>	 <p><b>1103F</b> BOWL COVER GASKET</p>	 <p><b>1104F</b> BOWLCOVER GASKET</p>
---	---	---

**REFERENCE**

**WALKER CARBURETOR  
KIT #151000B**

# HITACHI

**"APPLICATION"**

**ISUZU (4 cyl).....1991-86  
NISSAN (4 cyl).....1985-83**

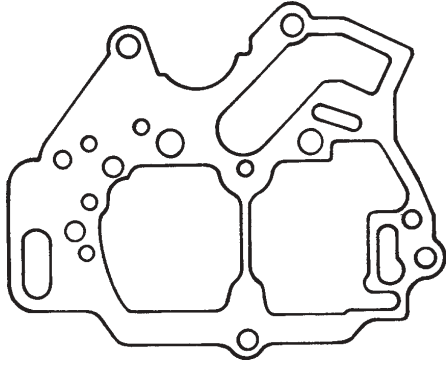

**1125F  
BOWL COVER GASKET**

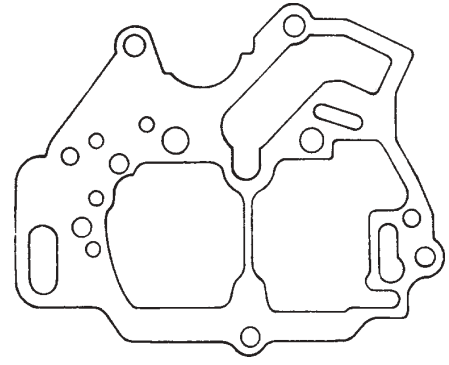

**1126F  
BOWL COVER GASKET**

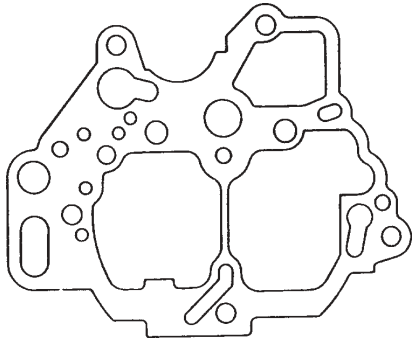

**1098F  
BOWL COVER  
GASKET**

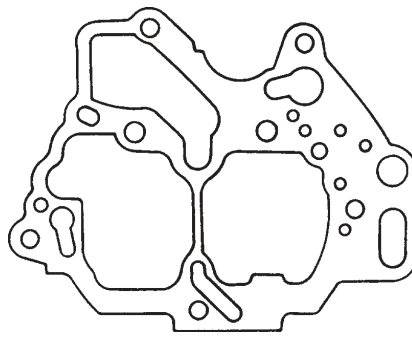

**1099F  
BOWL COVER  
GASKET**

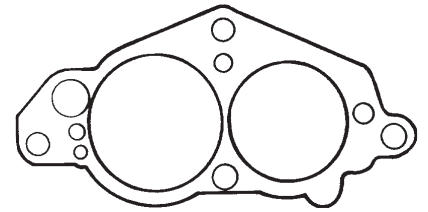

**1127F  
THROTTLE BODY  
GASKET**

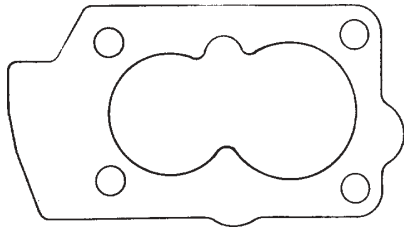

**1002F  
FLANGE GASKET  
SKIN**

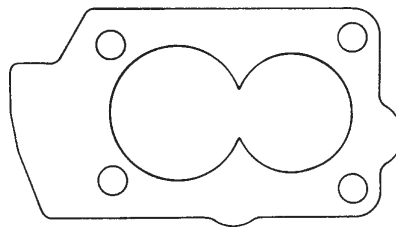

**1105F  
FLANGE GASKET  
SKIN**

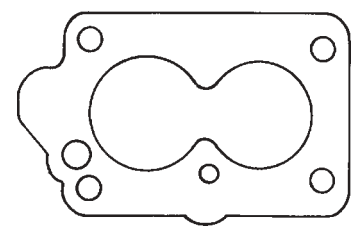

**1128F  
FLANGE GASKET  
SKIN**



**916F  
CHOKE COVER  
POP RIVET**

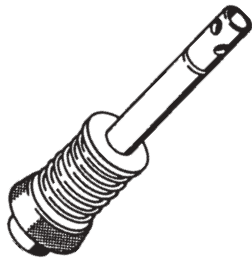

**832F  
PUMP PLUGER  
ASSEMBLY**



**477F  
PUMP PLUNGER  
BOOT**



**1152F  
PUMP PLUNGER  
BOOT**



**1100F  
THROTTLE SHAFT  
SEAL**

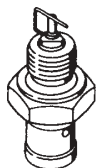

**31-670  
NEEDLE & SEAT  
ASSEMBLY**



**REFERENCE**

**WALKER CARBURETOR  
KIT #151001**

# HITACHI



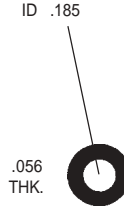
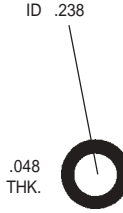
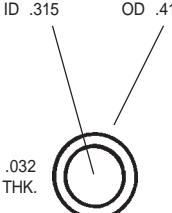

**"APPLICATION"**

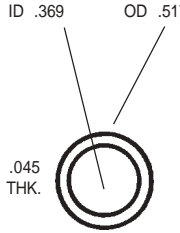
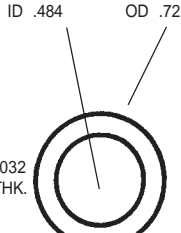
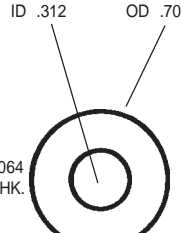
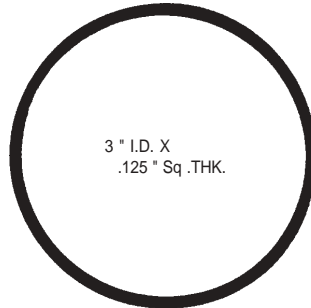
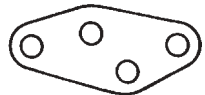
**NISSAN (4 cyl).....1984**

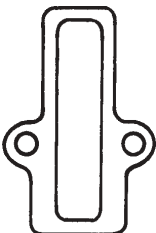
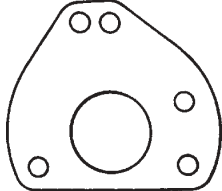
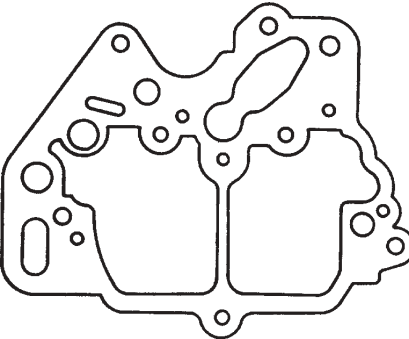
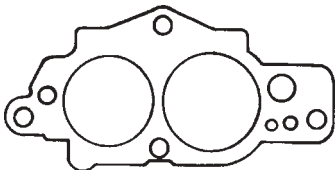
 <p><b>90-12</b> CHECK BALL 5/32" STEEL</p>	 <p><b>62-57</b> "E" CLIP RETAINER</p>	 <p><b>G495</b> RUBBER CHOKE HOUSING WASHER</p>	 <p><b>795F</b> PUMP DISCHARGE NOZZLE O-RING</p>	 <p><b>G929</b> VACUUM PISTON SEAL O-RING</p>	 <p><b>G59</b> FUEL INLET WASHER</p>
--	---	--	---	---	---

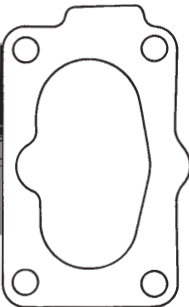
 <p><b>2F</b> NEEDLE SEAT WASHER</p>	 <p><b>11F</b> BANJO UNION BOLT WASHER</p>	 <p><b>74F</b> UPPER INLET BANJO WASHER</p>	 <p><b>333F</b> RUBBER FUEL WINDOW SEAL</p>	 <p><b>357F</b> SEC. DIAPHRAGM GASKET</p>
--	---	--	---	--

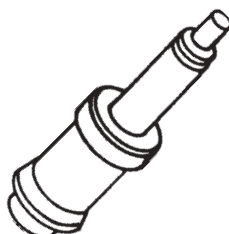
 <p><b>906F</b> IDLE COMPENSATOR GASKET</p>	 <p><b>362F</b> CONTROL UNIT GASKET</p>	 <p><b>1080F</b> BOWLCOVER GASKET</p>	 <p><b>985F</b> THROTTLE BODY GASKET</p>
--	--	---	---

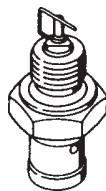
 <p><b>519F</b> FLANGE GASKET</p>	 <p><b>916F</b> CHOKE COVER POP RIVET</p>	 <p><b>866F</b> PUMP PLUNGER ASSEMBLY</p>	 <p><b>862F</b> PUMP PLUNGER BOOT</p>	 <p><b>31-670</b> NEEDLE &amp; SEAT ASSEMBLY</p>
--	--	--	---	---









**REFERENCE**







**WALKER CARBURETOR  
KIT #151013**

# HITACHI



**"APPLICATION"**

**NISSAN (4 cyl).....1987-84**

 <p><b>90-12</b> CHECK BALL 5/32" STEEL</p>	 <p><b>62-90</b> "E" CLIP RETAINER</p>	 <p><b>32-11</b> COTTER PIN</p>	 <p>ID .185 .056 THK.</p> <p><b>795F</b> PUMP DISCHARGE NOZZLE O-RING</p>	 <p>ID .238 .048 THK.</p> <p><b>G929</b> VACUUM PISTON SEAL O-RING</p>	 <p>ID .276 .059 THK.</p> <p><b>1007F</b> LOWER FEEDBACK O-RING</p>
--	---	--	---	---	--

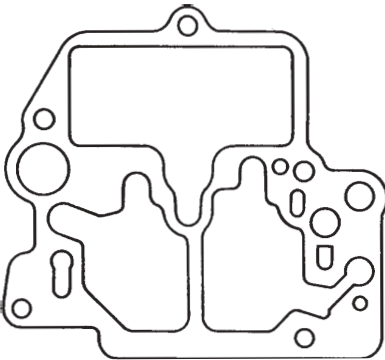
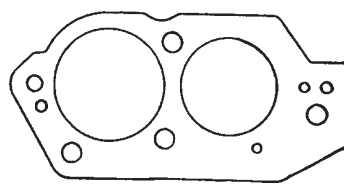
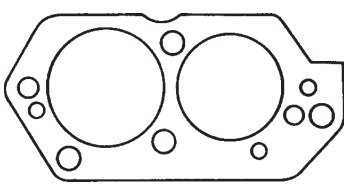
 <p>ID .270 .053 THK.</p> <p><b>775F</b> O-RING</p>	 <p>ID .354 .059 THK.</p> <p><b>1006F</b> UPPER FEEDBACK O-RING</p>	 <p>ID .364 OD .498 .046 THK.</p> <p><b>608F</b> MAIN JET WASHER</p>	 <p>ID .484 OD .721 .032 THK.</p> <p><b>11F</b> BANJO UNION BOLT WASHER</p>	 <p>ID .595 OD .871 .031 THK.</p> <p><b>1060F</b> FLOAT BOWL WINDOW GASKET</p>	 <p>ID .720 .095 THK.</p> <p><b>932F</b> O-RING SEAL</p>
--	--	---	--	---	---

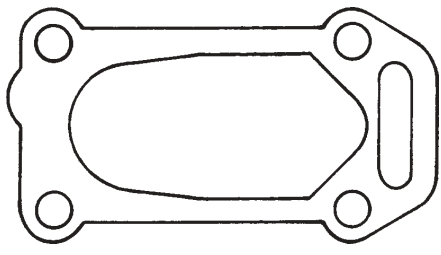
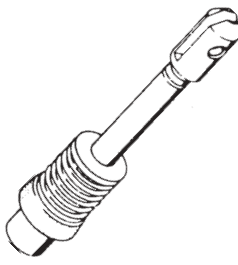
 <p><b>1062F</b> BOWL COVER GASKET</p>	 <p><b>1145F</b> THROTTLE BODY GASKET</p>	 <p><b>1061F</b> THROTTLE BODY GASKET</p>
---	---	--

 <p><b>1148F</b> FLANGE GASKET SKIN</p>	 <p><b>1017F</b> PUMP PLUNGER ASSEMBLY</p>	 <p><b>547F</b> PUMP PLUNGER BOOT</p>	 <p><b>31-661</b> NEEDLE &amp; SEAT ASSEMBLY</p>
--	---	--	---



















**REFERENCE**

**WALKER CARBURETOR  
KIT #151026A**

# HITACHI

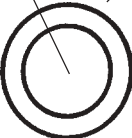
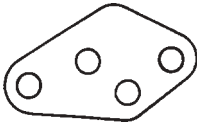
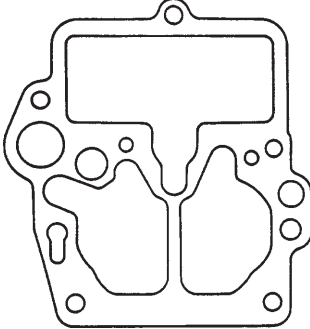
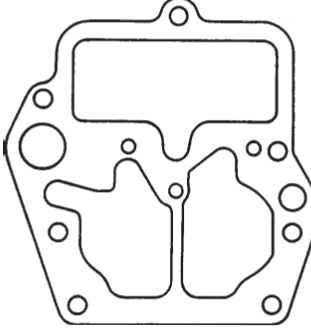
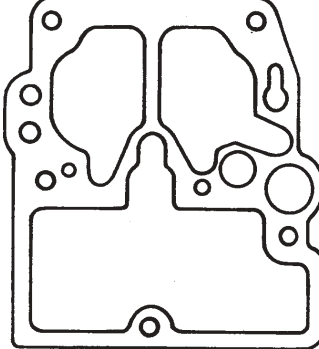
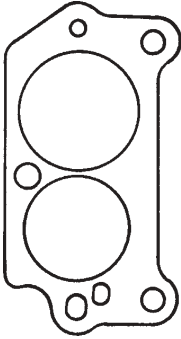
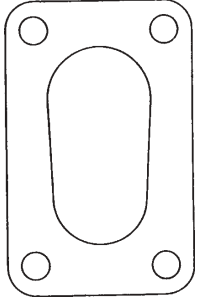
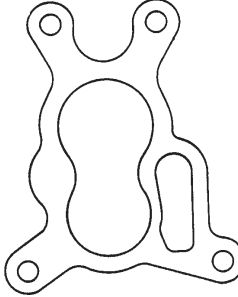
**"APPLICATION"**

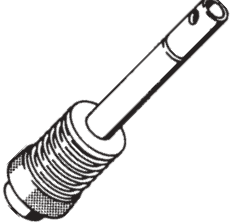
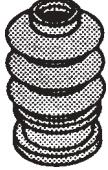
**MAZDA (4 cyl).....1985-84**

 <p><b>90-39</b> CHECK BALL 5/32" NYLON</p>	 <p><b>90-12</b> CHECK BALL 5/32" STEEL</p>	 <p><b>90-13</b> CHECK BALL 3/16" STEEL</p>	 <p><b>32-11</b> COTTER PIN</p>	 <p><b>32-10</b> COTTER PIN</p>	 <p>ID .185 .056 THK.</p> <p><b>795F</b> PUMP DISCHARGE NOZZLE O-RING</p>
 <p>ID .238 .048 THK.</p> <p><b>G929</b> VACUUM PISTON SEAL O-RING</p>	 <p>ID .276 .059 THK.</p> <p><b>1007F</b> LOWER FEEDBACK O-RING</p>	 <p>ID .232 OD .376 .032 THK.</p> <p><b>G1240</b> THROTTLE BODY SCREW GASKET</p>	 <p>ID .315 OD .411 .032 THK.</p> <p><b>G59</b> FUEL INLET WASHER</p>	 <p>ID .354 .059 THK.</p> <p><b>1006F</b> UPPER FEEDBACK O-RING</p>	 <p>ID .364 OD .498 .046 THK.</p> <p><b>608F</b> FIBER JET WASHER</p>
 <p>ID .476 .060 THK.</p> <p><b>685F</b> THROTTLE BYPASS VALVE O-RING</p>	 <p>ID .541 .052 THK.</p> <p><b>733F</b> BOWL VENT SOLENOID O-RING</p>	 <p>ID .484 OD .721 .032 THK.</p> <p><b>11F</b> BANJO UNION BOLT WASHER</p>	 <p><b>576F</b> SEC. DIAPHRAGM MOUNTING GASKET</p>		
 <p><b>1038F</b> BOWL COVER GASKET</p>	 <p><b>1039F</b> BOWL COVER GASKET</p>	 <p><b>1045F</b> BOWL COVER GASKET</p>	 <p><b>1040F</b> THROTTLE BODY GASKET</p>		
 <p><b>486F</b> FLANGE GASKET</p>	 <p><b>660F</b> FLANGE GASKET</p>	 <p><b>905F</b> CHOKE COVER POP RIVET</p>	 <p><b>764F</b> PUMP PLUNGER ASSEMBLY</p>	 <p><b>547F</b> PUMP PLUNGER BOOT</p>	 <p><b>31-659</b> NEEDLE &amp; SEAT ASSEMBLY</p>

















**REFERENCE**

**WALKER CARBURETOR  
KIT #151046**

# HITACHI

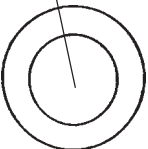
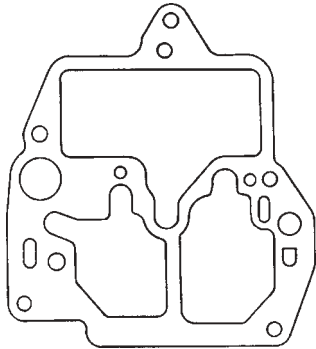
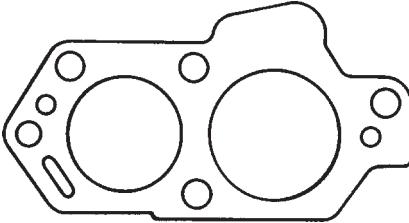
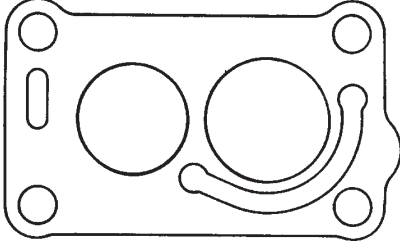
**"APPLICATION"**

**CHEVROLET (Sprint) (3 cyl)..1986-85**

 <p><b>90-12</b> CHECK BALL 5/32" STEEL</p>	 <p><b>62-57</b> "E" CLIP RETAINER</p>	 <p><b>62-90</b> "E" CLIP RETAINER</p>	 <p>ID .185 .056 THK.</p> <p><b>795F</b> PUMP DISCHARGE NOZZLE O-RING</p>	 <p>ID .238 .048 THK.</p> <p><b>G929</b> VACUUM PISTON SEAL O-RING</p>	 <p>ID .276 .059 THK.</p> <p><b>1007F</b> LOWER FEEDBACK O-RING</p>
 <p>ID .354 .059 THK.</p> <p><b>1006F</b> UPPER FEEDBACK O-RING</p>	 <p>ID .364 OD .498 .046 THK.</p> <p><b>608F</b> MAIN JET WASHER</p>	 <p>ID .468 .078 THK.</p> <p><b>700F</b> AIR VALVE O-RING</p>	 <p>ID .476 .060 THK.</p> <p><b>685F</b> THROTTLE BYPASS VALVE O-RING</p>	 <p>ID .541 .052 THK.</p> <p><b>733F</b> BOWL VENT SOLENOID O-RING</p>	 <p>ID .484 OD .721 .032 THK.</p> <p><b>11F</b> BANJO UNION BOLT WASHER</p>
 <p>ID .454 OD .750 .020 THK.</p> <p><b>1052F</b> BOWL WINDOW GASKET</p>	 <p><b>1113F</b> BOWL COVER GASKET</p>	 <p><b>1114F</b> THROTTLE BODY GASKET</p>			
 <p><b>1115F</b> FLANGE GASKET SKIN</p>	 <p><b>983F</b> PUMP PLUNGER ASSEMBLY</p>	 <p><b>547F</b> PUMP PLUNGER BOOT</p>	 <p><b>31-661</b> NEEDLE &amp; SEAT ASSEMBLY</p>		

**REFERENCE**

**WALKER CARBURETOR  
KIT #151051**

# HITACHI

**"APPLICATION"**

**SUBARU (4 cyl).....1987-85**



**90-39**  
CHECK BALL  
5/32" NYLON



**62-90**  
"E" CLIP  
RETAINER



**32-10**  
COTTER PIN

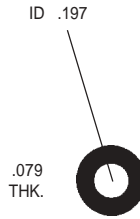

**1041F**  
IDLE MIXTURE  
SCREW O-RING

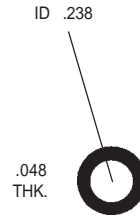

**G929**  
VACUUM PISTON  
SEAL O-RING

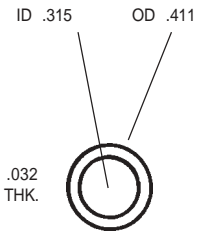

**G59**  
FUEL INLET  
WASHER

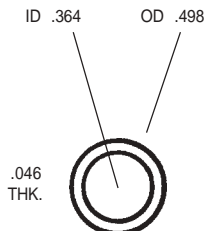

**608F**  
MAIN JET  
WASHER

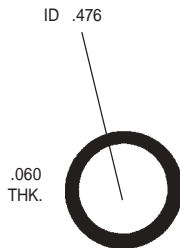

**685F**  
THROTTLE BYPASS  
VALVE O-RING

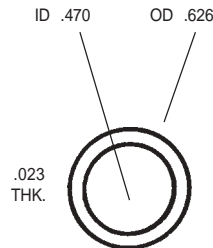

**912F**  
COPPER NEEDLE  
SEAT GASKET

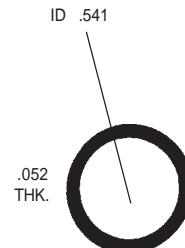

**733F**  
BOWL VENT  
SOLENOID O-RING

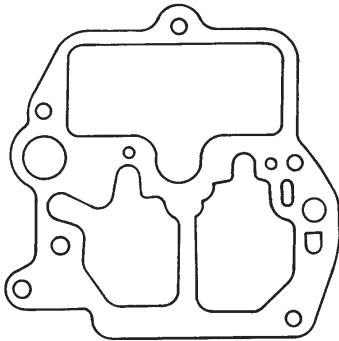

**990F**  
BOWL COVER  
GASKET

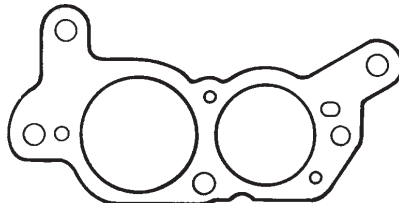

**1053F**  
THROTTLE BODY  
GASKET

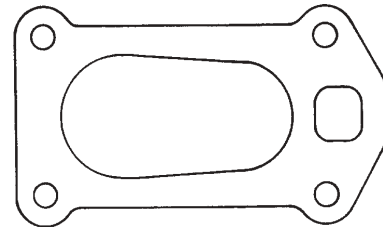

**1054F**  
FLANGE GASKET



**916F**  
CHOKE COVER POP  
RIVET

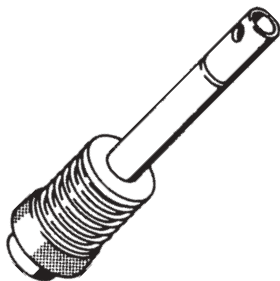

**764F**  
PUMP PLUNGER  
ASSEMBLY



**547F**  
PUMP PLUNGER  
BOOT



**31-657**  
NEEDLE & SEAT  
ASSEMBLY







**REFERENCE**





**WALKER CARBURETOR  
KIT #151071A**

# HITACHI





**"APPLICATION"**

**SUBARU (4 cyl).....1992-87**

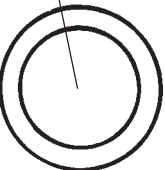
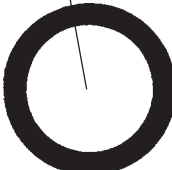
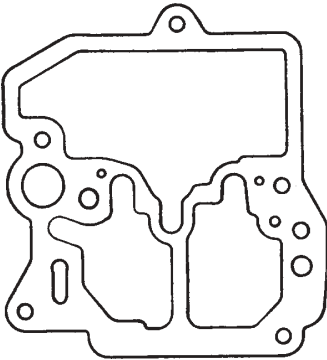
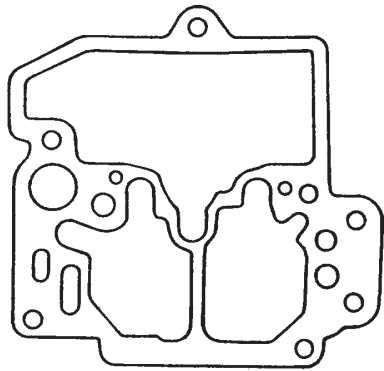
				ID .256  .059 THK.	ID .239  .040 THK.
<b>90-12</b> CHECK BALL 5/32" STEEL	<b>62-63</b> "E" CLIP RETAINER	<b>32-11</b> COTTER PIN	<b>32-20</b> COTTER PIN	<b>1140F</b> O-RING	<b>1150F</b> VENTURI O-RING

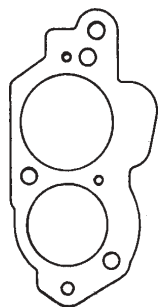
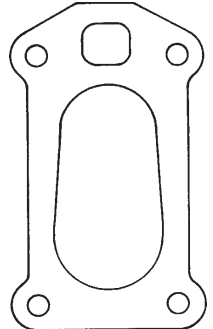
ID .354  .059 THK.	ID .359 OD .478  .024 THK.	ID .485 OD .626  .032 THK.	ID .476  .060 THK.	ID .551  .070 THK.
<b>1006F</b> UPPER FEEDBACK O-RING	<b>1271F</b> NEEDLE SEAT GASKET	<b>215F</b> FUEL VALVE SEAT WASHER	<b>685F</b> THROTTLE BYPASS VALVE O-RING	<b>707F</b> DAMPER O-RING

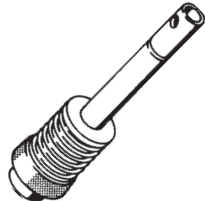
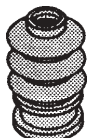
ID .605 OD .859  .032 THK.	ID .720  .095 THK.		
<b>G112</b> BOWL STRAINER GASKET	<b>932F</b> O-RING SEAL	<b>1143F</b> BOWL COVER GASKET	<b>1245F</b> BOWL COVER GASKET

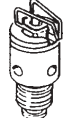
					
<b>1144F</b> THROTTLE BODY GASKET	<b>1054F</b> FLANGE GASKET	<b>916F</b> CHOKE COVER POP RIVET	<b>764F</b> PUMP PLUNGER ASSEMBLY	<b>547F</b> PUMP PLUNGER BOOT	<b>G652</b> VACUUM TUBE CAP 5/32" I.D.
					
					<b>31-674</b> NEEDLE & SEAT ASSEMBLY











**REFERENCE**

WALKER CARBURETOR  
KIT #151072

# HITACHI

**"APPLICATION"**

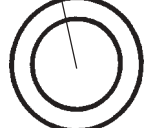
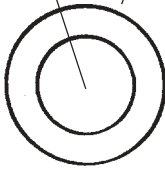
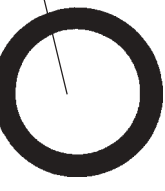
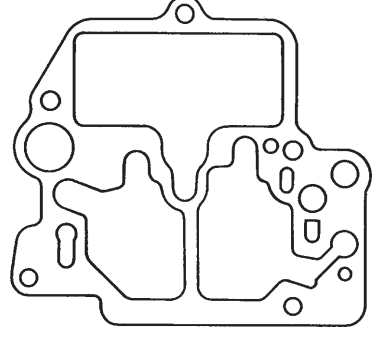
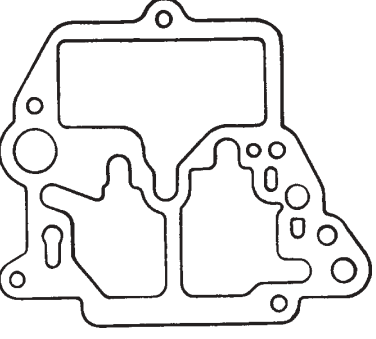
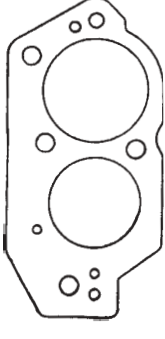
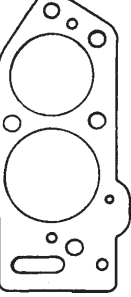
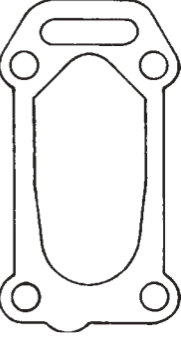
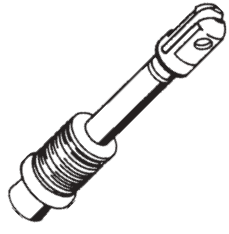
NISSAN (4 cyl).....1988-86

 <p><b>90-12</b> CHECK BALL 5/32" STEEL</p>	 <p><b>62-90</b> "E" CLIP RETAINER</p>	 <p><b>32-11</b> COTTER PIN</p>	 <p>ID .185 .056 THK.</p> <p><b>795F</b> PUMP DISCHARGE NOZZLE O-RING</p>	 <p>ID .238 .048 THK.</p> <p><b>G929</b> VACUUM PISTON SEAL O-RING</p>	 <p>ID .276 .059 THK.</p> <p><b>1007F</b> LOWER FEEDBACK O-RING</p>
 <p>ID .270 .053 THK.</p> <p><b>775F</b> O-RING</p>	 <p>ID .354 .059 THK.</p> <p><b>1006F</b> UPPER FEEDBACK O-RING</p>	 <p>ID .364 OD .498 .046 THK.</p> <p><b>608F</b> MAIN JET WASHER</p>	 <p>ID .484 OD .721 .032 THK.</p> <p><b>11F</b> BANJO UNION BOLT WASHER</p>	 <p>ID .595 OD .871 .031 THK.</p> <p><b>1060F</b> FLOAT BOWL WINDOW GASKET</p>	
 <p>ID .720 .095 THK.</p> <p><b>932F</b> O-RING SEAL</p>	 <p><b>1062F</b> BOWL COVER GASKET</p>	 <p><b>1146F</b> BOWL COVER GASKET</p>	 <p><b>1145F</b> THROTTLE BODY GASKET</p>		
 <p><b>1147F</b> THROTTLE BODY GASKET</p>	 <p><b>1148F</b> FLANGE GASKET SKIN</p>	 <p><b>1162F</b> PUMP PLUNGER ASSEMBLY</p>	 <p><b>547F</b> PUMP PLUNGER BOOT</p>	 <p><b>31-661</b> NEEDLE &amp; SEAT ASSEMBLY</p>	







**REFERENCE**







**WALKER CARBURETOR  
KIT #151101A**

# HITACHI



**"APPLICATION"**

**CHEVROLET (3 cyl).....1986-85  
SUZUKI (4 cyl).....1989-86**

  <p><b>90-12 CHECK BALL 5/32" STEEL</b></p>	 <p><b>62-90 "E" CLIP RETAINER</b></p> <hr/>  <p><b>62-57 "E" CLIP RETAINER</b></p>	  <p><b>32-55 COTTER PIN</b></p>	 <p>ID .185 .056 THK.</p> <p><b>795F PUMP DISCHARGE NOZZLE O-RING</b></p>	 <p>ID .238 .048 THK.</p> <p><b>G929 VACUUM PISTON SEAL O-RING</b></p>	 <p>ID .276 .059 THK.</p> <p><b>1007F LOWER FEEDBACK O-RING</b></p>
---	---	---	--	--	---

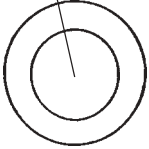
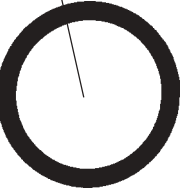
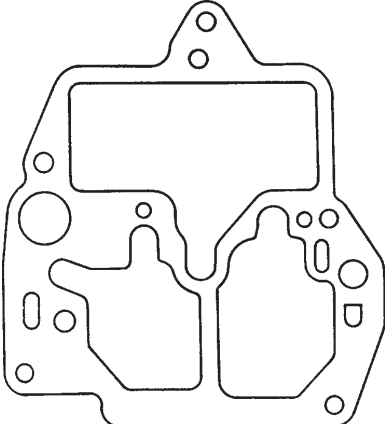
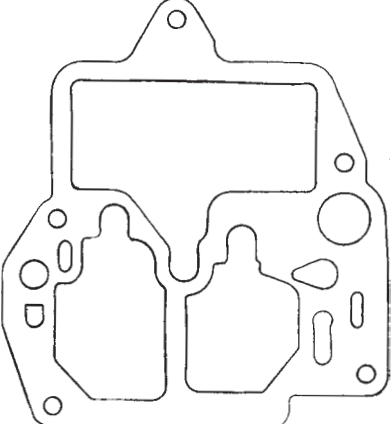
 <p>ID .354 .059 THK.</p> <p><b>1006F UPPER FEEDBACK O-RING</b></p>	 <p>ID .364 OD .498 .046 THK.</p> <p><b>608F MAIN JET WASHER</b></p>	 <p>ID .468 .078 THK.</p> <p><b>700F AIR VALVE O-RING</b></p>	 <p>ID .476 .060 THK.</p> <p><b>685F THROTTLE BYPASS VALVE O-RING</b></p>	 <p>ID .541 .052 THK.</p> <p><b>733F BOWL VENT SOLENOID O-RING</b></p>	 <p>ID .484 OD .721 .032 THK.</p> <p><b>11F BANJO UNION BOLT WASHER</b></p>
---	--	---	--	--	---

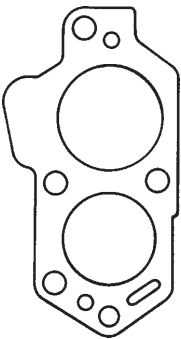
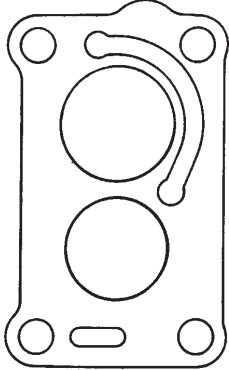
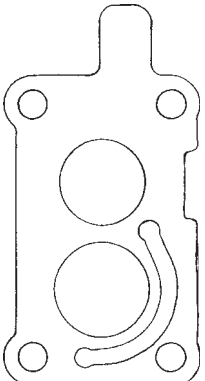
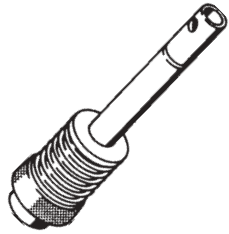
 <p>ID .454 OD .750 .020 THK.</p> <p><b>1052F BOWL WINDOW GASKET</b></p>	 <p>ID .772 .094 THK.</p> <p><b>G1544 O-RING</b></p>	 <p><b>1113F BOWL COVER GASKET</b></p>	 <p><b>1276F BOWL COVER GASKET</b></p>
--	--	--	---

 <p><b>1114F THROTTLE BODY GASKET</b></p>	 <p><b>1115F FLANGE GASKET SKIN</b></p>	 <p><b>1277F FLANGE GASKET SKIN</b></p>	 <p><b>505F PUMP PLUNGER ASSEMBLY</b></p>	 <p><b>31-661 NEEDLE &amp; SEAT ASSEMBLY</b></p> <hr/>  <p><b>547F PUMP PLUNGER BOOT</b></p>
---	---	---	---	--